

ERIC JOHNSON THINLINE STRAT (0113602XXX)

PARTS LAYOUT

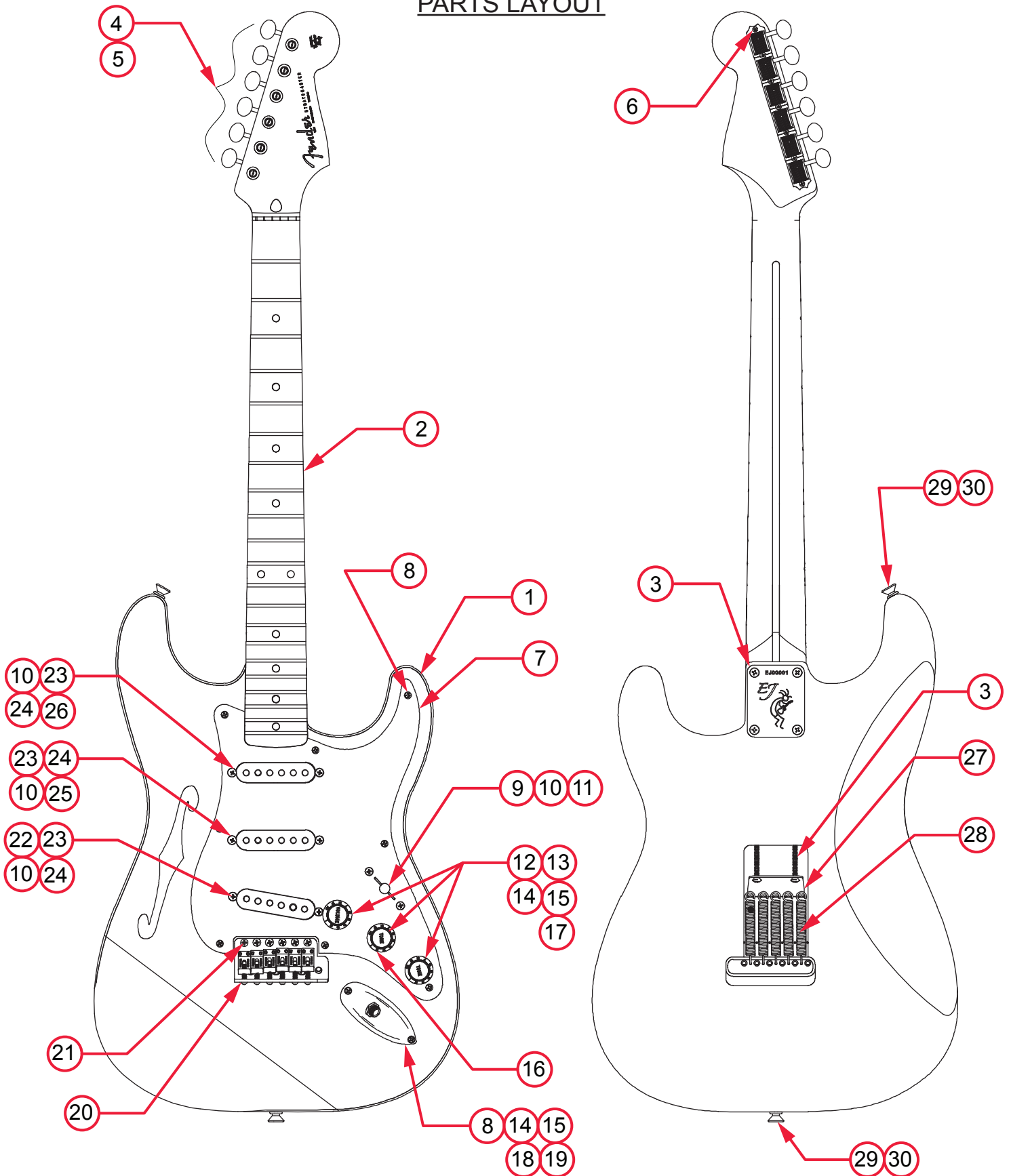

ERIC JOHNSON THINLINE STRAT (0113602XXX)

PARTS LIST

REF#	DESCRIPTION	PART NUMBER
1	BODY E.JOHNSON THINLINE STRAT 2TSB	7712366503
1	BODY E.JOHNSON THINLINE STRAT VWT	7712366541
2	NECK ASSY ERIC JOHNSON STRAT MPL	0068930000
3	SCREWS SMA 8 X 1-3/4 OHP NI	0015636049
4	KEY SET VINT HSG STAGGERED NK	0068927000
5	BUSHING KEY ERIC JOHNSON STRAT	0068932000
6	SCREWS SMAB 3 X 3/8 RHP STL NI	0011357049
7	PICKGUARD 56 STRAT PARCH	0053841000
8	SCREWS SMAB 4 X 1/2 OHP NI	0015578049
9	SWITCH 5-WAY LEVER	0991367000
10	SCREWS M 6-32 X 5/8 OHP NI	0015776049
11	KNOB P/U SWITCH VINT AGED WHT	0994938000
12	KNOBS VOL/TONE AGED WHITE SET	0991369000
13	CONTROL 250K 10% TPR SPLIT	0990830000
14	NUTS HEX 3/8-32 X 3/32 TK NI	0016352049
15	WASHERS LOCK INTL 3/8 X .687	0016436049
16	CAP CERAMIC DISC .10MFD 1KV	0068989000
17	SHIELD ALUM VINTAGE STRAT	0019640049
18	FERRULE JACK CHROME	0991940100
19	JACK PHONE OPEN CIRCT 11	0021956049
20	BRIDGE ASSY EJ STRAT	0068937000
20A	BRIDGE PLATE VINT STRAT	0019470000
20B	BLOCK TREMOLO EJ STRAT	0068938000
20C	SCREWS M 8-32 X 3/8 FHP NI	0019656049
20D	BRIDGE SECTION ASSY VINT STRAT NI SHORT	0019280101
20E	SPRING BRIDGE #1933	0019273049
20F	SCREWES M 4-40 X 5/8 RHP NI	0015693049
20G	BRIDGE SECTION ASSY VINT STRAT NI TALL	0019280102
20H	SPRING BRIDGE #1932	0019281049
21	SCREWS WD RD PH 6 X 1-1/8 NI	0016170049
22	PICKUP STRAT EJ BRIDGE	0068936000
23	COVERS PICKUP VINT STRAT AGED WHITE	0053824049
24	TUBING LATEX CUT .300 X 1/8ID X 1/4OD	0994916000
25	PICKUP STRAT EJ MID REV	0068935000
26	PICKUP STRAT EJ NECK	0068934000

*= NOT PICTURED IN DIAGRAM



ERIC JOHNSON THINLINE STRAT (0113602XXX)

WIRING ASSEMBLY

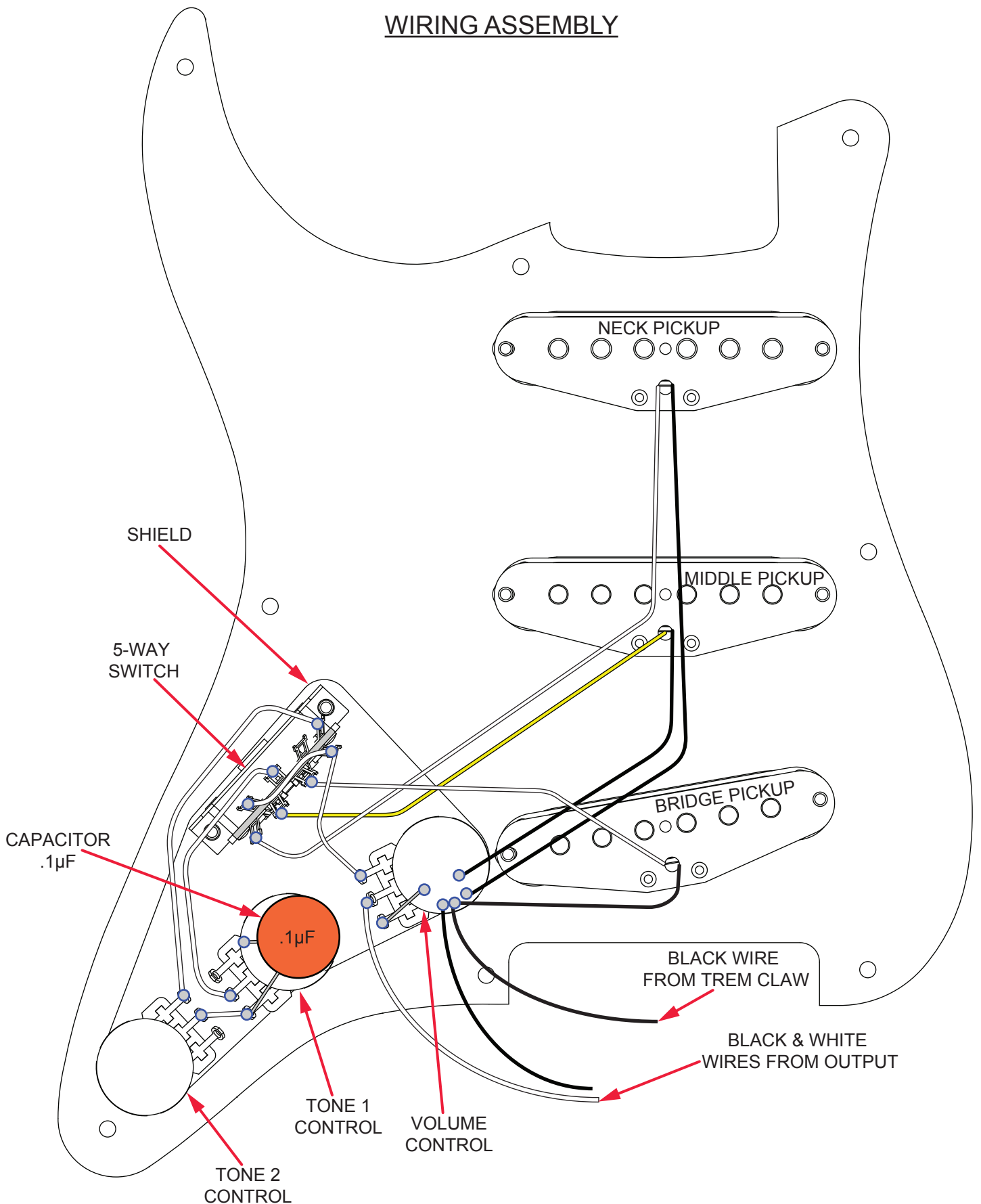

ERIC JOHNSON THINLINE STRAT (0113602XXX)

SWITCH AND CONTROL FUNCTION

5 WAY SWITCH POSITION					
T1	T1	NO TONE	T2	T2	← CONTROL
					← NECK PICKUP
					← MIDDLE PICKUP
					← BRIDGE PICKUP
PICKUP IS ON PICKUP IS OFF				INDICATES POSITION OF 5 WAY SWITCH	

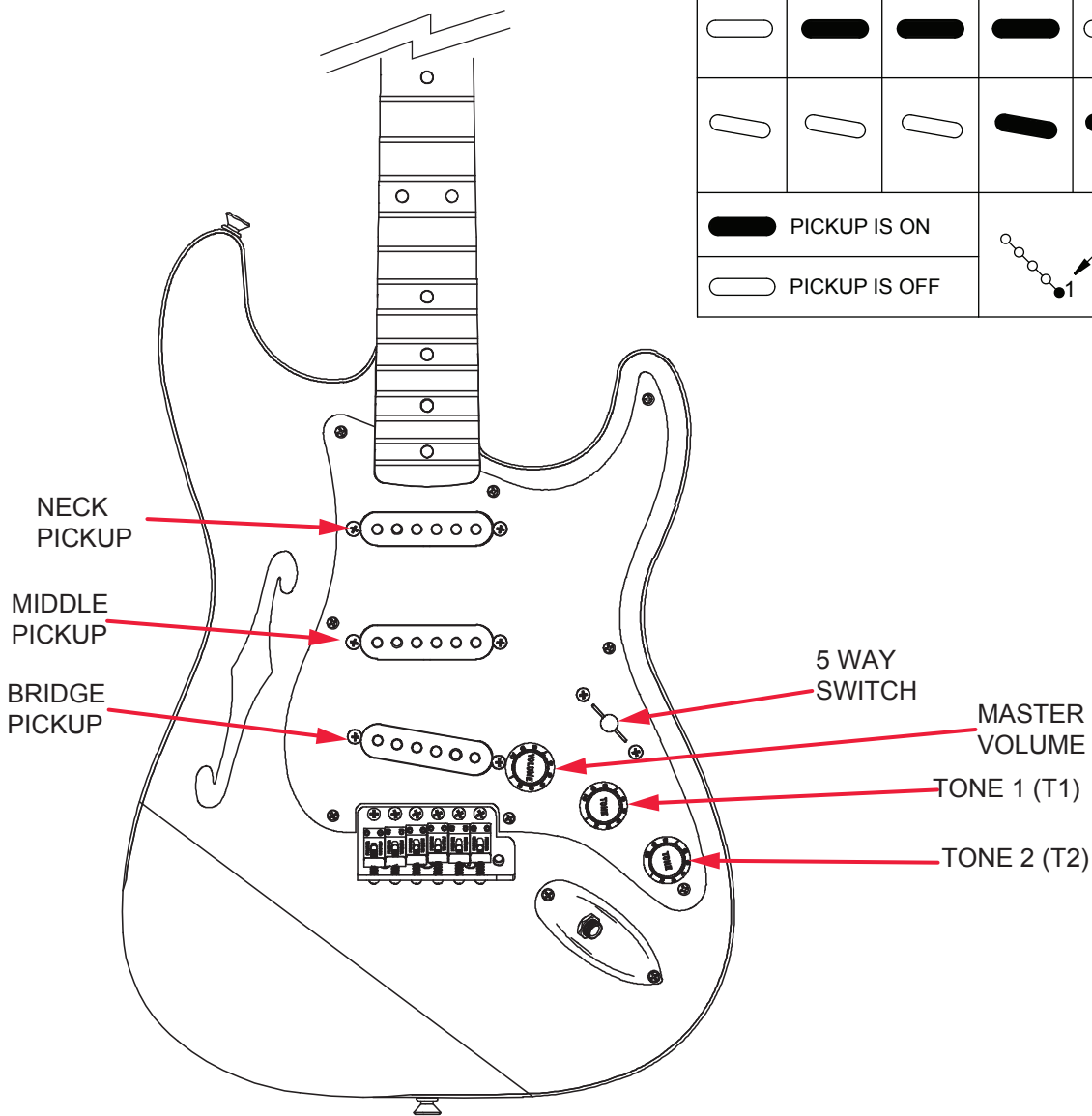

ERIC JOHNSON THINLINE STRAT (0113602XXX)

ADDITIONAL SPECIFICATION DETAIL

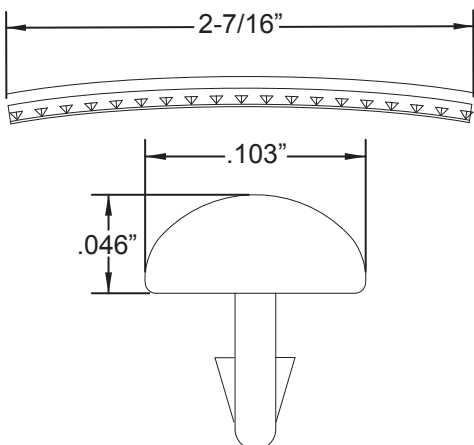
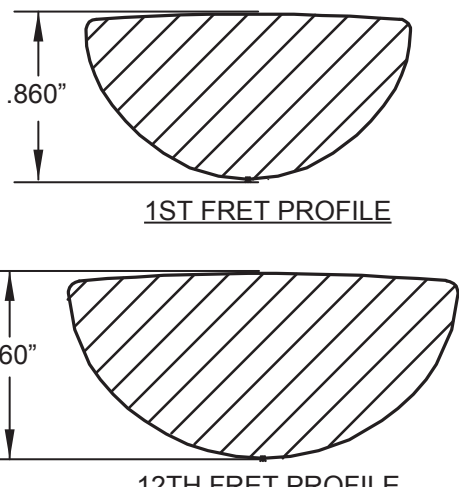
<p>FRET SIZE: MEDIUM JUMBO (FRET DIMENSIONS ARE BEFORE INSTALLATION)</p> 	<p>PLEASE NOTE: AS EACH NECK IS SANDED & FINISHED BY HAND, THICKNESS DIMENSIONS MAY VARY SLIGHTLY FROM THOSE SHOWN.</p>	<p>NECK PROFILE: ERIC JOHNSON</p>  <p>1ST FRET PROFILE</p> <p>12TH FRET PROFILE</p>
---	---	---

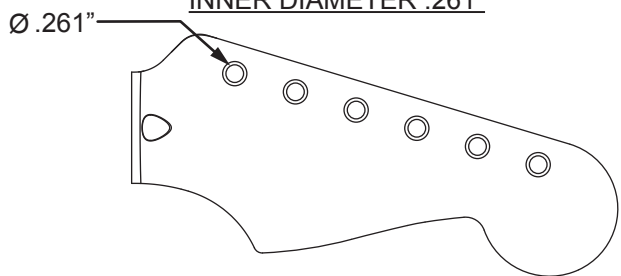
<p>STAGGERED TUNING MACHINE SET P/N 0068927000 <u>OUTER SHAFT DIAMETER .250"</u></p>  <p>Ø .250"</p>	<p>TUNING MACHINE THRU-HOLE <u>INNER DIAMETER .261"</u></p>  <p>Ø .261"</p>
---	---

SADDLE HEIGHT ADJUSTMENT WRENCH:
.050" HEX KEY P/N 0018531049

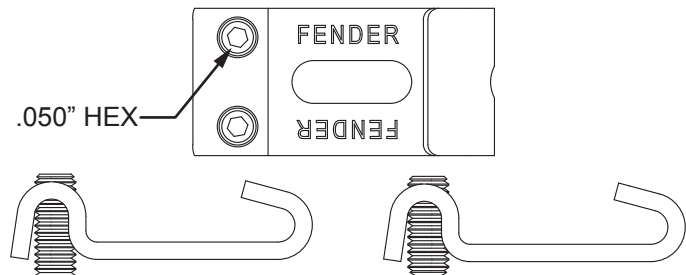

.050" HEX

SADDLE HEIGHT ADJUSTMENT SCREWS:
TALL: P/N 0075384000 SHORT: P/N 0075536000

TRUSS ROD NUT P/N 0994944000

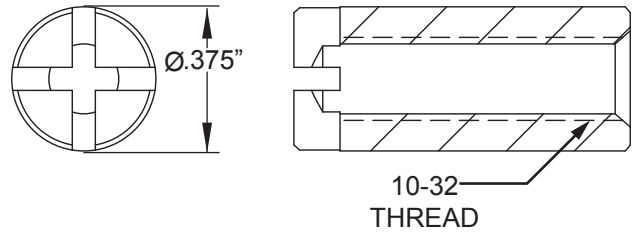

Ø.375"

10-32
THREAD

LOGO: VINTAGE STRATOCASTER
APPLIED OVER THE FINISH



PICKUP SPECIFICATIONS			
POSITION	MAGNETS	DC RESISTANCE	POLARITY
NECK	ALNICO 5 UNBEVELED	5.8 - 6.0KΩ	NORTH
MIDDLE	ALNICO 5 UNBEVELED	6.3 - 6.5KΩ	SOUTH
BRIDGE	ALNICO 5 UNBEVELED	6.7 - 6.9KΩ	NORTH

