

Powered Mixer

MODEL #3208



One of a family of four powered mixers in the Fender Pro-Sound line, the 3208 is a state-of-the-art mixing console of high quality combined with a powerful and rugged amplifier. The 3208 achieves performance in all respects as good as separate components, allowing its use in even the most demanding professional applications.

FEATURES

Each of the eight input channels features balanced transformerless Lo-z and Hi-z inputs and a channel "insertion" point. The insertion point is effectively "moveable" between pre and post EQ positions by the use of the front panel "pre-post insertion" control.

Input channels have three band, five frequency, input EQ (mid-band switchable 750Hz, 1.5kHz, 3.0kHz), signal present and peak LEDs, a trim control with 40dB range to optimize pre-amp gain and a pan control between the main output busses plus two monitors, one effects buss and a 60mm slide fader.

The effects bus is normaled through an internal spring reverb, but accessible as an echo send and return on the rear panel. Lo-z XLR mic connectors carry 48 volt Phantom power selected through an on/off switch on the rear of the mixer.

The meter panel carries four Vu meters with "peak" LEDs, these meters monitor main and monitor outputs, while the power amp output is monitored by two clip LEDs. Under the clip LEDs are the switches for the power amplifier "AGC" (Automatic Gain Control), for each amp channel.

Four nine band graphic equalizers, two main, two monitor, a program and effects return input and pan control and the four master faders complete the front panel controls.

Extensive system interstage patch points allow the re-arrangement of many of the features of the mixer to allow specific requirements to be met. All input and output levels and impedances are matched and suitable for this purpose.

The mixer section of the 3200 series is of the highest

quality with very low distortion and noise, allowing the use of this kind of product for professional sound contracting and high quality live sound reinforcement.

The built-in amplifiers are of essentially the same design as the highly acclaimed Fender 2224 and 2244 series power amplifiers. These amplifiers are designed to produce their rated power into highly reactive and low impedance loads, and are provided with forced-air cooled heat dissipators. Delivering in excess of 200 watts per channel into 4 ohms with great sonic accuracy, the amplifiers exceed the specs and performance of many of the best "separate" products available. The "AGC" limiting circuit effectively eliminates clipping, without degrading the quality of the signal.

The 3200 series has exceptional stability even well beyond its normal intended operational limits, allowing its successful use in high demand situations. High headroom and correct internal grounding procedures add to the overall sonic performance of the line.

Packaged in a compact enclosure and fitted with unique "pointer" type color-coded knobs and BNC connectors, for optional panel light, the powered mixer presents itself as an attractive and professional product that will give many years of reliable service.

The 3200 series powered mixers are supplied with an extensive 73 page "Owners/Applications" manual that is a most valuable resource for the user and operator in not only the operation of the 3200 series but all aspects of sound reinforcement. For the sound contractor this manual offers an effective means of training the operator and assuring the best operation of a system as it was designed and installed.

Block Diagram, Model 3208

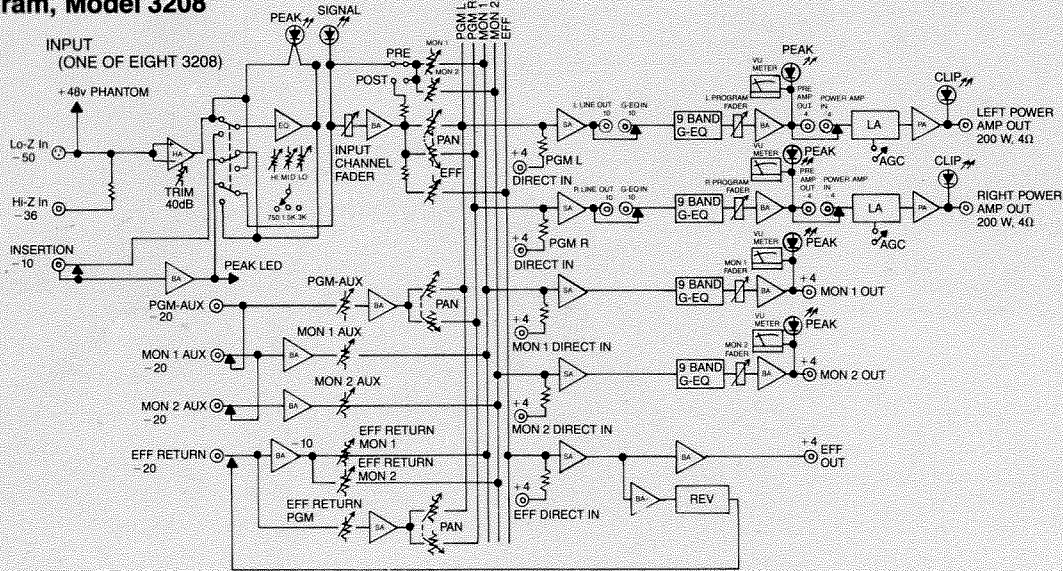

Frequency response:

Power amplifier: 20Hz to 20kHz, +0, -1/2dB @ 200 watts output.

Mixer: 20Hz to 20kHz ±2dB.

T.H.D.:

Power amplifier: Less than 0.1% 20Hz to 20kHz at 200 watts output.

Mixer: Less than 0.1% from 20Hz to 20kHz at +18dB output at pre-amp out. Typically 0.05%.

Hum and Noise:

Mixer: EIN -129dBm, 20Hz-20kHz. 150 termination.

Power amp: Greater than 100dB (signal to noise ratio).

Crosstalk:

-60dB @ 1kHz, between all signal paths.

C.M.R.R.:

60dB at 1000Hz (external noise rejection).

Channel Equalization:

High: ±15dB @ 10kHz, shelving.
Mid: ±12dB @ .750, 1.5, 3.0kHz. Peaking and dipping.
Low: ±15dB @ 100Hz, Shelving.

Graphic Equalization:

Metering: 4 illuminated Vu. Program Left and Right. Monitor 1 and 2.

Indicators:

Channel Signal present and peak. Vu meter peak @ 10dB before clip. Phantom on. Power Amplifier Clip. AGC Operation, LEDs.

Voltage Amplification:

101dB, ±2dB (maximum). Lo-z input to Power Amp out.

"0" Vu reference:

+4dB at Pre-Amp out.

Maximum Input level:

Lo-z Input Greater than +10dB. Hi-z Input Greater than +24dB.

Power Output:

200 watts into 4 ohms, per channel.

Phantom Power:

48 volts DC on pins 2 and 3 of Lo-z (mic) input. Rear panel switch. Silent turn on.

Power Requirements:

120 volts (±10%) 60Hz.

Safety Listing:

UL.

Dimensions:

3208
Depth 675mm (26.6")
Width 680mm (26.7")
Height 185mm (7.3")
Weight 27 kg (59.4 lbs)

INPUTS	MAX. VOLTAGE GAIN (20' LOG VO/VI)		SOURCE TYPE	ACTUAL INPUT IMPEDANCE	INPUT VOLTAGES NOMINAL	MAX BEFORE CLIP
	TO L,R PRE AMP OUT	TO L,R POWER AMP OUT				
INSERTION (INPUT)	34dB	61dB	LO OR HI-Z LOW-LEVEL LINE	50K-OHMS	-10dB (245 mv)	+20dB (7.75 VOLT)
HI-Z IN	60dB	87dB	HI-Z MIC OR LINE INSTRUMENT DIRECT	20K-OHMS (BAL)	-36dB TO +4dB (12.3 mv) TO 1.23 VOLTS	+24dB (12.3 VOLT)
LO-Z IN	74dB	101dB	LO-Z MIC OR LOW-LEVEL 600-OHM LINE	5K-OHMS (BAL)	-50dB TO -10dB (2.45 mv) TO 245 mv	+10dB (2.45 VOLT)
L,R DIRECT IN (PROGRAM)	0dB	27dB	LO OR HI-Z LINE	110K-OHMS (1.23 VOLT)	+4dB (38.8 VOLT)	+34dB (38.8 VOLT)
L,R G-EQ IN	24dB	51dB	LO OR HI-Z LINE	50K-OHMS	-10dB (245 mv)	+20dB (7.75 VOLT)
L,R POWER AMP IN		27dB	LO OR HI-Z LINE	16K-OHMS	+4dB (1.23 VOLT)	+4dB (1.23 VOLT)
EFF RETURN	34dB	61dB	LOW-LEVEL LINE	33K-OHMS	-20dB (7.75 mv)	+10dB (2.45 VOLT)
EFF DIRECT			LO OR HI-Z LINE	110K-OHMS	+4dB (1.23 VOLT)	+34dB (38.8 VOLT)
PGM AUX IN	34dB	61dB	LO OR HI-Z LOW-LEVEL LINE	33K-OHMS	-20dB (7.75 mv)	+34dB (38.8 VOLT)
MON 1, 2 DIRECT IN			LO OR HI-Z LINE	110K-OHMS	+4dB (1.23 VOLT)	+34dB (38.8 VOLT)
MON 1, 2 AUX IN			LO OR HI-Z LOW-LEVEL LINE	50K-OHMS	-20dB (7.75 mv)	+10dB (2.45 VOLT)

OUTPUTS	LOAD TYPE NOMINAL	ACTUAL OUTPUT IMPEDANCE	OUTPUT VOLTAGES NOMINAL	
				MAX BEFORE CLIP
INSERTION (OUTPUT)	10K-OHM LINE	100-OHMS	-10dB (245 mv)	+20dB (7.75 VOLT)
L,R LINE OUT	10K-OHM LINE	100-OHMS	+4dB (1.23 VOLT)	+20dB (7.75 VOLT)
L,R PRE AMP OUT	10K-OHM LINE	100-OHMS	+4dB (1.23 VOLT)	+20dB (7.75 VOLT)
L,R POWER AMP OUT	4-OHM (MINIMUM) LOUDSPEAKER		200-WATTS MAX INTO 4-OHMS	
EFF OUT	10K-OHM LINE	100-OHMS	+4dB (1.23 VOLT)	+20dB (7.75 VOLT)
MON 1, 2 OUT	10K-OHM LINE	100-OHMS	+4dB (1.23 VOLT)	+20dB (7.75 VOLT)

Specifications subject to change without notice. © 1984 CBS Inc.



QUICK REFERENCE GUIDE (Models 3208, 3212, 3216)

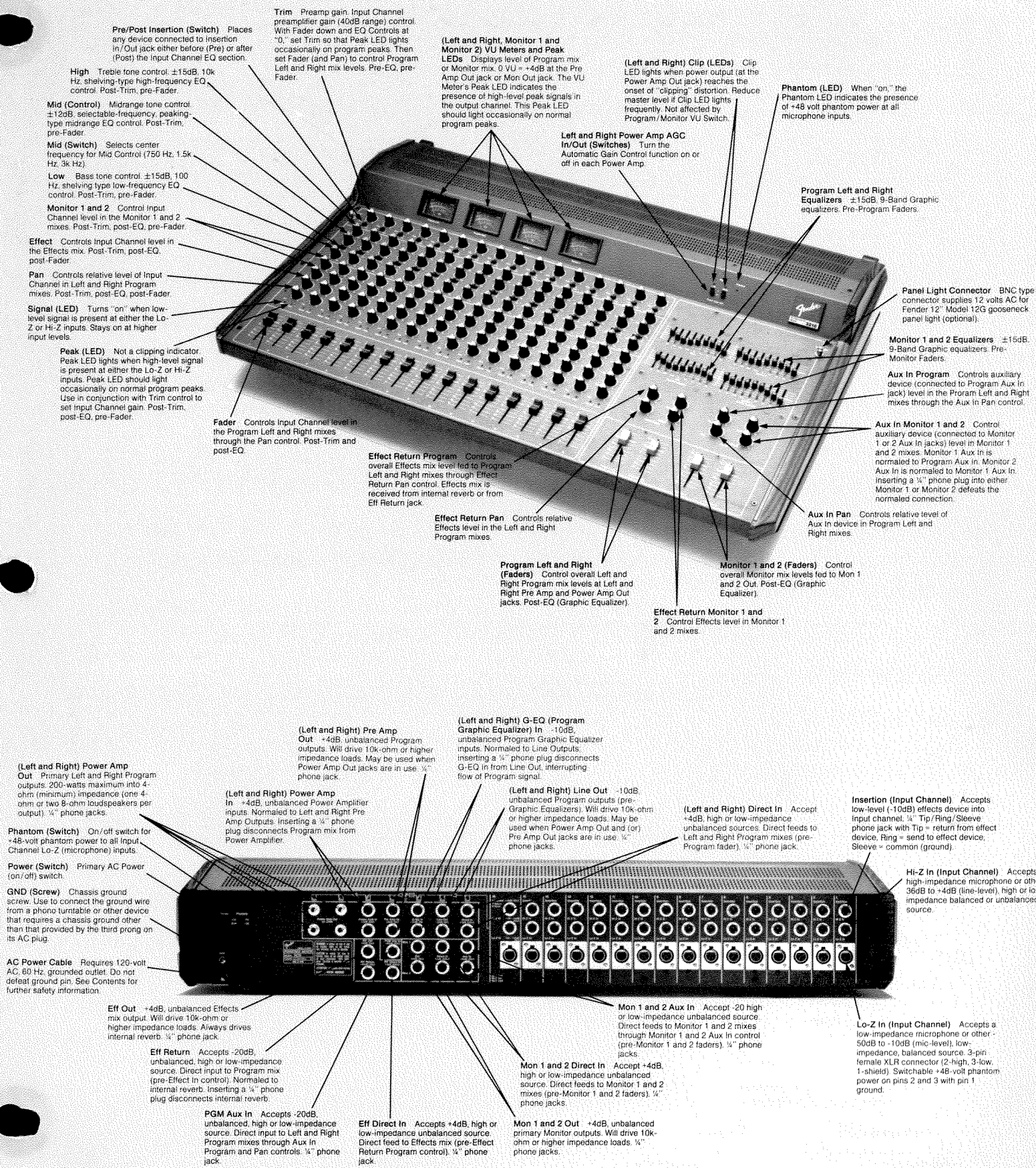

Pre/Post Insertion (Switch) Places any device connected to insertion in / Out jack either before (Pre) or after (Post) the input Channel EQ section.

High Treble tone control. $\pm 15\text{dB}$. 10k Hz, shelving-type high-frequency EQ control. Post-Trim, pre-Fader.

Mid (Control) Midrange tone control. $\pm 12\text{dB}$, selectable-frequency, peaking-type midrange EQ control. Post-Trim, pre-Fader.

Mid (Switch) Selects center frequency for Mid Control (750 Hz, 1.5k Hz, 3k Hz).

Low Bass tone control. $\pm 15\text{dB}$. 100 Hz, shelving-type low-frequency EQ control. Post-Trim, pre-Fader.

Monitor 1 and 2 Control input Channel level in the Monitor 1 and 2 mixes. Post-Trim, post-EQ, pre-Fader.

Effect Controls input Channel level in the Effects mix. Post-Trim, post-EQ, post-Fader.

Pan Controls relative level of Input Channel in Left and Right Program mixes. Post-Trim, post-EQ, post-Fader.

Signal (LED) Turns "on" when low-level signal is present at either the Lo-Z or Hi-Z inputs. Stays on at higher input levels.

Peak (LED) Not a clipping indicator. Peak LED lights when high-level signal is present at either the Lo-Z or Hi-Z inputs. Peak LED should light occasionally on normal program peaks. Use in conjunction with Trim control to set input Channel gain. Post-Trim, post-EQ, pre-Fader.

Fader Controls input Channel level in the Program Left and Right mixes through the Pan control. Post-Trim and post-EQ.

Effect Return Program Controls overall Effects mix level fed to Program Left and Right mixes through Effect Return Pan control. Effects mix is received from internal reverb or from Eff Return jack.

Effect Return Pan Controls relative Effects level in the Left and Right Program mixes.

Program Left and Right (Faders) Control overall Left and Right Program mix levels at Left and Right Pre Amp and Power Amp Out jacks. Post-EQ (Graphic Equalizer).

Monitor 1 and 2 (Faders) Control overall Monitor mix levels fed to Mon 1 and 2 Out. Post-EQ (Graphic Equalizer).

Effect Return Monitor 1 and 2 Controls Effects level in Monitor 1 and 2 mixes.

(Left and Right, Monitor 1 and Monitor 2) VU Meters and Peak LEDs Displays level of Program mix or Monitor mix. 0 VU = $+4\text{dB}$ at the Pre Amp Out jack or Mon Out jack. The VU Meter's Peak LED indicates the presence of high-level peak signals in the output channel. This Peak LED should light occasionally on normal program peaks.

(Left and Right) Clip (LEDs) Clip LED lights when power output (at the Power Amp Out jack) reaches the onset of "clipping" distortion. Reduce master level if Clip LED lights frequently. Not affected by Program / Monitor VU Switch.

Phantom (LED) When "on," the Phantom LED indicates the presence of +48 volt phantom power at all microphone inputs.

Left and Right Power Amp AGC In/Out (Switches) Turn the Automatic Gain Control function on or off in each Power Amp.

Program Left and Right Equalizers $\pm 15\text{dB}$, 9-Band Graphic equalizers. Pre-Program Faders.

Panel Light Connector BNC type connector supplies 12 volts AC for Fender 12" Model 12G gooseneck panel light (optional).

Monitor 1 and 2 Equalizers $\pm 15\text{dB}$, 9-Band Graphic equalizers. Pre-Monitor Faders.

Aux In Program Controls auxiliary device (connected to Program Aux In jack) level in the Program Left and Right mixes through the Aux In Pan control.

Aux In Monitor 1 and 2 Control auxiliary device (connected to Monitor 1 or 2 Aux In jacks) level in Monitor 1 and 2 mixes. Monitor 1 Aux In is normalized to Program Aux In. Monitor 2 Aux In is normalized to Monitor 1 Aux In. Inserting a $\frac{1}{4}$ " phone plug into either Monitor 1 or Monitor 2 defeats the normalized connection.

Aux In Pan Controls relative level of Aux in device in Program Left and Right mixes.

(Left and Right) Power Amp Out Primary Left and Right Program outputs. 200-watts maximum into 4-ohm (minimum) impedance (one 4-ohm or two 8-ohm loudspeakers per output). $\frac{1}{4}$ " phone jacks.

Phantom (Switch) On/off switch for +48-volt phantom power to all Input Channel Lo-Z (microphone) inputs.

Power (Switch) Primary AC Power (on/off) switch.

GND (Screw) Chassis ground screw. Use to connect the ground wire from a phono turntable or other device that requires a chassis ground other than that provided by the third prong on its AC plug.

AC Power Cable Requires 120-volt AC, 60 Hz, grounded outlet. Do not defeat ground pin. See Contents for further safety information.

Eff Out +4dB, unbalanced Effects mix output. Will drive 10k-ohm or higher impedance loads. Always drives internal reverb. $\frac{1}{4}$ " phone jack.

Eff Return Accepts -20dB, unbalanced, high or low-impedance source. Direct input to Program mix (pre-Effect In control). Normalized to internal reverb. Inserting a $\frac{1}{4}$ " phone plug disconnects internal reverb.

PGM Aux In Accepts -20dB, unbalanced, high or low-impedance source. Direct input to Left and Right Program mixes through Aux In Program and Pan controls. $\frac{1}{4}$ " phone jack.

Eff Direct In Accepts +4dB, high or low-impedance unbalanced source. Direct feed to Effects mix (pre-Effect Return Program control). $\frac{1}{4}$ " phone jack.

Mon 1 and 2 Direct In Accepts +4dB, high or low-impedance unbalanced source. Direct feeds to Monitor 1 and 2 mixes (pre-Monitor 1 and 2 faders). $\frac{1}{4}$ " phone jacks.

Mon 1 and 2 Out +4dB, unbalanced primary Monitor outputs. Will drive 10k-ohm or higher impedance loads. $\frac{1}{4}$ " phone jacks.

(Left and Right) Pre Amp Out +4dB, unbalanced Program outputs. Will drive 10k-ohm or higher impedance loads. May be used when Power Amp Out jacks are in use. $\frac{1}{4}$ " phone jack.

(Left and Right) Power Amp In +4dB, unbalanced Power Amplifier inputs. Normalized to Left and Right Pre Amp Outputs. Inserting a $\frac{1}{4}$ " phone plug disconnects Program mix from Power Amplifier.

(Left and Right) G-EQ (Program Graphic Equalizer) In -10dB, unbalanced Program Graphic Equalizer inputs. Normalized to Line Outputs. Inserting a $\frac{1}{4}$ " phone plug disconnects G-EQ in from Line Out, interrupting flow of Program signal.

(Left and Right) Line Out -10dB, unbalanced Program outputs (pre-Graphic Equalizers). Will drive 10k-ohm or higher impedance loads. May be used when Power Amp Out and/or Pre Amp Out jacks are in use. $\frac{1}{4}$ " phone jacks.

(Left and Right) Direct In Accepts +4dB, high or low-impedance unbalanced sources. Direct feeds to Left and Right Program mixes (pre-Program fader). $\frac{1}{4}$ " phone jack.

Insertion (Input Channel) Accepts low-level (-10dB) effects device into input channel. $\frac{1}{4}$ " Tip / Ring / Sleeve phone jack with Tip = return from effect device, Ring = send to effect device, Sleeve = common (ground).

Hi-Z In (Input Channel) Accepts high-impedance microphone or other 36dB to +4dB (line-level), high or low-impedance balanced or unbalanced source.

Lo-Z In (Input Channel) Accepts a low-impedance microphone or other -50dB to -10dB (mic-level), low-impedance, balanced source. 3-pin female XLR connector (2 high, 3-low, 1-shield). Switchable +48-volt phantom power on pins 2 and 3 with pin 1 ground.