

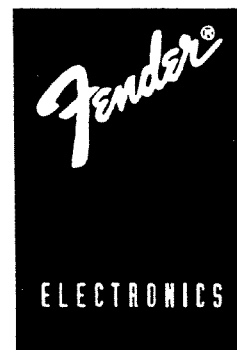
# Powered Mixers



From Fender Pro Audio

Owner's Manual for  
SR-4150P, SR-6300P  
SR-8300P, SR-6520P  
and SR-8520P

P/N 041245



# TABLE OF CONTENTS

## 1. OVERVIEW

- 1-1. BLOCK DIAGRAM
- 1-2. INTRODUCTION

## 2. FRONT PANEL CONTROLS, JACKS, AND LEDS

- 2-1. INPUT JACKS
  - 2-1-1. 1/4" JACKS
  - 2-1-2. XLR JACKS
- 2-2. CHANNEL CONTROLS
  - 2-2-1. CHANNEL LEVEL CONTROL
  - 2-2-2. CHANNEL TONE CONTROL
  - 2-2-3. EFF/REV CONTROL
  - 2-2-4. MONITOR CONTROL
- 2-3. MASTER SECTION CONTROLS
  - 2-3-1. MAIN LEVEL CONTROL
  - 2-3-2. MONITOR LEVEL CONTROL
  - 2-3-3. REVERB CONTROL
  - 2-3-4. MONITOR REVERB CONTROL
  - 2-3-5. EFF SEND CONTROL
  - 2-3-6. AUX LEVEL CONTROL
  - 2-3-7. GRAPHIC EQUALIZER
- 2-4. PATCH BAY
  - 2-4-1. MAIN OUT
  - 2-4-2. MONITOR OUT
  - 2-4-3. EFFECTS OUT
  - 2-4-4. GRAPHIC EQ OUT
  - 2-4-5. GRAPHIC EQ IN
  - 2-4-6. AUX IN
  - 2-4-7. TAPE IN
  - 2-4-8. POWER AMP IN
- 2-5. LEDS
  - 2-5-1. POWER LED
  - 2-5-2. PEAK LED
  - 2-5-3. PHANTOM POWER LED

## 3. BACK PANEL

- 3-1. SPEAKER OUTPUT JACKS
- 3-2. POWER SWITCH
- 3-3. POWER CORD

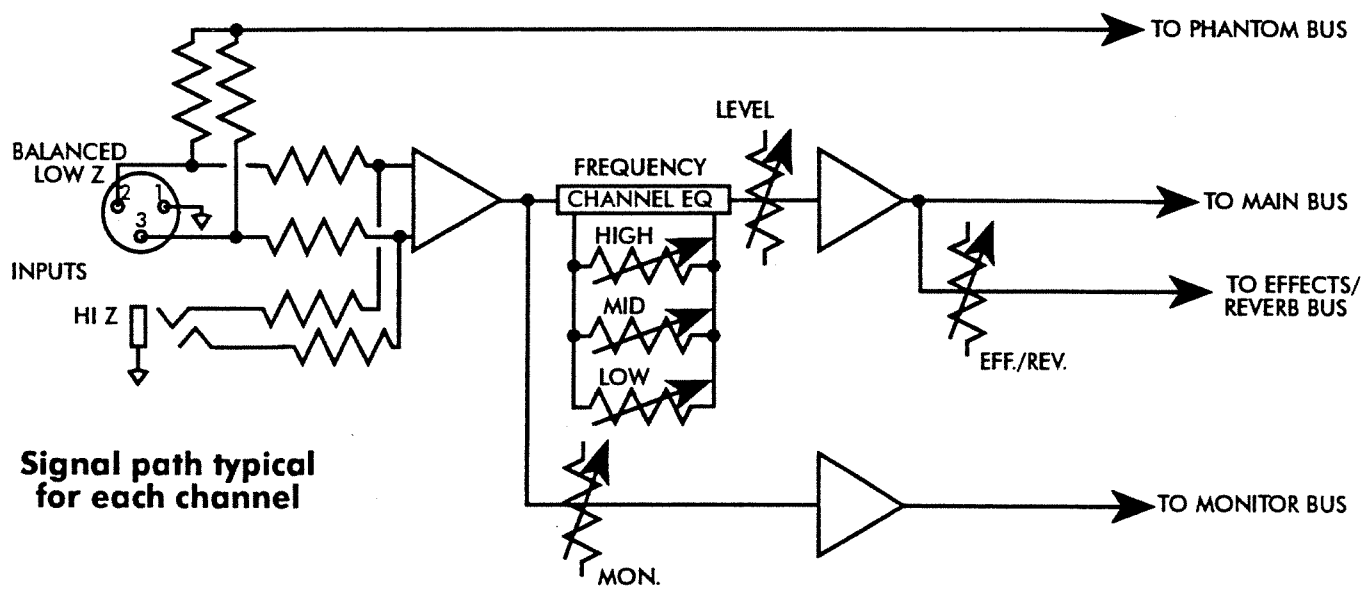
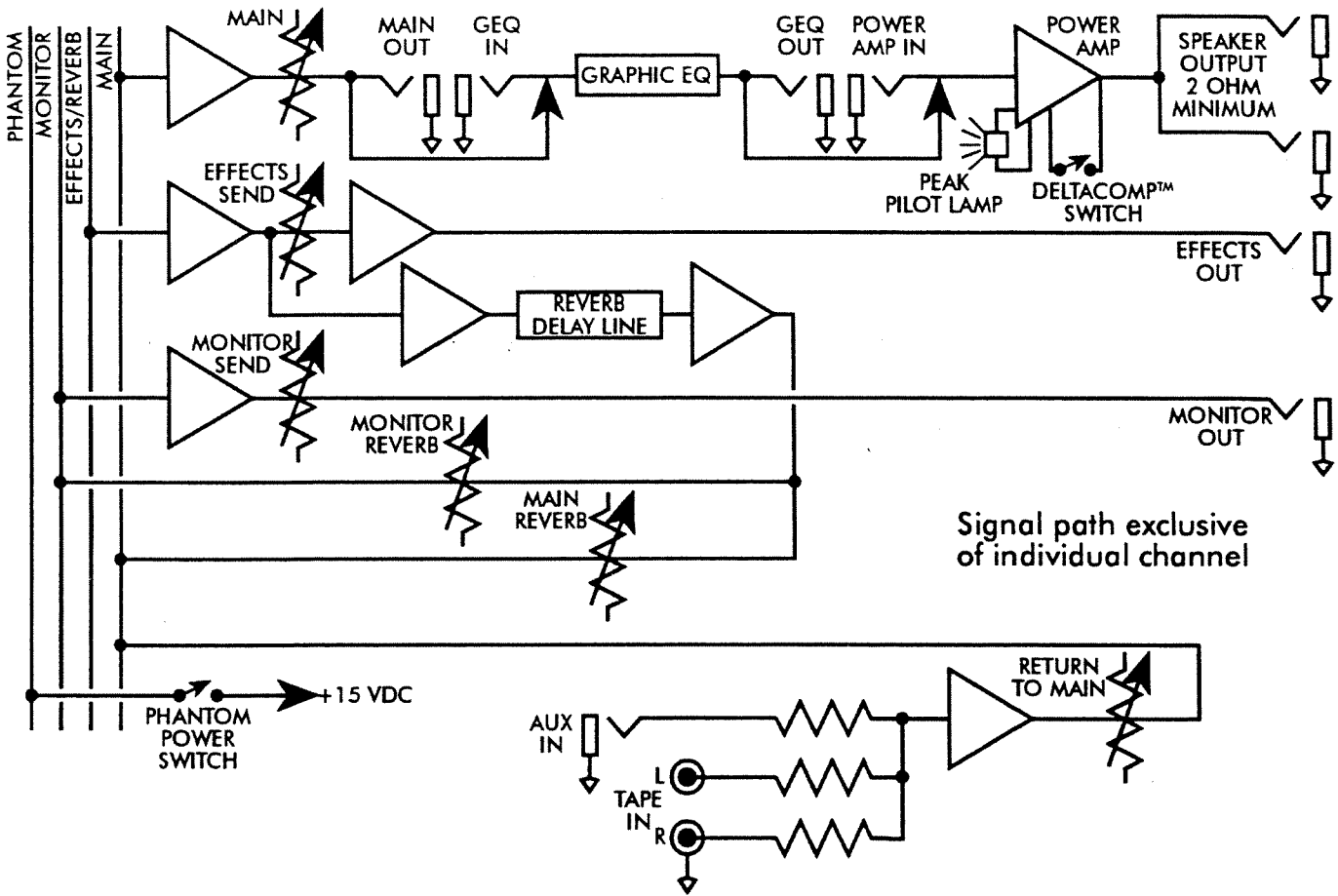
## 4. SETUP AND OPERATION

- 4-1-1. INITIAL PRESETS
- 4-1-2. LEVEL CONTROL
- 4-1-3. MONITOR CONTROLS
- 4-1-4. CHANNEL TONE CONTROLS
- 4-1-5. GRAPHIC EQUALIZER
- 4-2. USING THE THE GRAPHIC EQUALIZER TO ELIMINATE ACOUSTIC FEEDBACK
  - 4-2-1. THE CAUSE OF ACOUSTIC FEEDBACK
  - 4-2-2. TYPICAL PROCEDURE FOR ROOM EQUALIZATION
- 4-3. CORDS AND CABLES
  - 4-3-1. MICROPHONE CORDS
  - 4-3-2. SPEAKER CABLES
- 4-4. INPUT PADS
- 4-5. PATCHING

## 5. UPKEEP AND SERVICE

## 6. SPECIFICATIONS

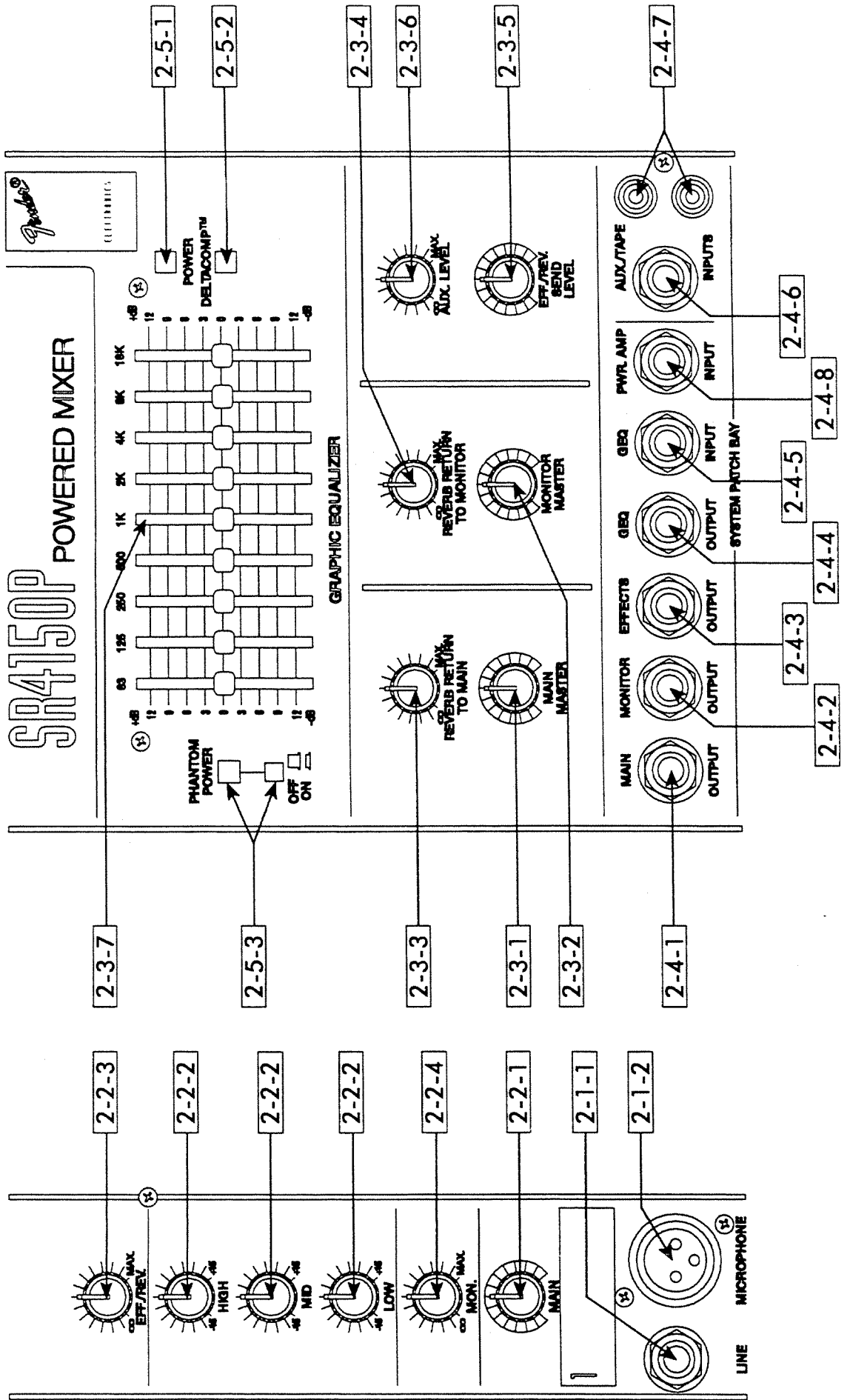
# 1-1 Block Diagram



# FRONT PANEL CONTROLS

## CHANNEL CONTROLS

## MASTER SECTION CONTROLS



## 1. OVERVIEW.

### 1-2. INTRODUCTION.

The SR series integrated mixer/amplifiers have been designed for easy setup and simple but versatile operation. Requiring only the addition of microphones and speakers, the SR powered mixers are self-contained sound reinforcement systems, with features and performance generally found only in units costing much more.

Each input preamp channel provides a balanced XLR microphone input with switchable phantom power for condenser microphones, a 1/4" phone jack input, Level control, Low, Mid, and High frequency equalization controls, Monitor send level control and an Effects/Reverb send level control.

The master section features Main, Monitor and Reverb master level controls, a graphic Equalizer, a power amplifier, and a versatile patch bay.

The SR series mixers include DELTACOMP™, an adaptive compression system. DELTACOMP™ is a high performance power amp limiter that senses amplifier error due to clipping, and automatically reduces the gain until the distortion is minimized. A front panel PEAK LED indicates the status of the limiter. If the power amp input is clipping, the yellow LED will be on.

To make setup as simple as possible, the mixer, graphic equalizer, and power amplifier are pre-patched in a standard configuration that requires plugging in only the microphones and speakers to be "on the air." To make the system as versatile as possible, this "normalized" patch may be bypassed by using the inputs and outputs of the patch bay. These allow the individual components of the system to be used in various combinations, and for external equipment to be added into the system as the need arises.

The SR Series has been designed to meet the needs of professionals, and can be counted on to provide reliable service in the most demanding situations.

1-1. BLOCK DIAGRAM. The block diagram found on the back page illustrates the typical signal path for the SR series.

## 2. FRONT PANEL CONTROLS, JACKS AND LEDs.

2-1-1. 1/4" JACKS. The 1/4" phone jacks are intended for high impedance balanced or unbalanced inputs whose amplitude is under 8 VRMS. This would include instrument and line level signals. When used as a balanced input, the tip connection of the 1/4" jack is the non-inverting (+) input and the ring connection is the inverting (-) input.

2-1-2. XLR JACKS. The three-pin audio connectors (often called "XLR" or "Cannon" connectors) on the front panel are intended for balanced input signals from low impedance microphones. To avoid clipping

in the input stage, signal levels should not exceed 0.8 VRMS. Higher amplitude signals, such as balanced line level signals, may also be patched into these jacks if an input pad is used (see Section 4-4). The XLR jack is wired according to the following standard:

Pin 1 is ground.

Pin 2 is the non-inverting (+) input.

Pin 3 is the inverting (-) input.

Signals at the XLR jacks experience 20 dB more gain than those at the 1/4" channel input jacks.

### 2-2. CHANNEL CONTROLS.

2-2-1. CHANNEL LEVEL CONTROL. The channel LEVEL control determines how much of the channel's signal is sent to the Main mixing buss and to the EFF/REV control. For best signal to noise ratio, this control should be set relatively high; usual settings are around 2 o'clock, except when input signal levels are great enough to cause clipping. See Section 4-1-2.

2-2-2. CHANNEL TONE CONTROLS. The LOW, MID, and HIGH controls on each channel may be adjusted to enhance the qualities of its particular audio signal and to control excessive boominess or sibilance ("s" sounds) by using the LOW, MID, and HIGH controls. When these controls are at 0 (straight up), the channel is "flat" (no frequencies cut or boosted). The most natural sound is achieved by avoiding extreme tone control settings.

2-2-3. EFF/REV SEND LEVEL CONTROL. This control determines how much signal from each channel goes onto the Effects/Reverb buss. All signals on this buss are combined in the master mixer section, and sent both to the EFFECTS OUT jack and to the internal reverb system. The EFF/REV control is wired post-LEVEL control and post-EQ; thus, the level and tone of the EFF/REV signal are altered by the settings of the LEVEL, LOW, MID, and HIGH controls.

2-2-4. MONITOR CONTROL. The MONITOR control determines how much of a channel's signal is sent to the Monitor buss. This allows a separate mix to be created for stage monitoring. The control is wired pre-LEVEL control and pre-EQ; thus, the monitor signal is independent of other channel controls.

### 2-3. MASTER SECTION CONTROLS.

2-3-1. MAIN MIX MASTER LEVEL CONTROL. This is the master level control for the main mix. It controls the signal level present at the MAIN OUT jack, if nothing is patched into the GRAPHIC IN jack or the POWER AMP IN jack, the MAIN LEVEL control also determines the graphic equalizer and power amplifier input levels.

2-3-2. MONITOR MIX MASTER LEVEL CONTROL. This is the master level control for the monitor mix. It controls the signal level present at the MONITOR OUT jack.

2-3-3. **MAIN MIX REVERB RETURN CONTROL.** This control determines how much of the signal from the reverb system is added or returned to the main mix.

2-3-4. **MONITOR MIX REVERB RETURN CONTROL.** The **MONITOR REVERB RETURN LEVEL** control determines how much of the signal from the reverb system is added to the monitor mix. Many vocalists like to hear some reverb on their voices in the monitor system; be aware that reverb in the monitors increases the likelihood of feedback in the monitor system due to increased gain.

2-3-5. **EFF./REV. SEND MASTER LEVEL CONTROL.** The mix created by the settings of the channel **EFF/REV** controls appears at the **EFFECTS OUT** jack, as well as being sent to the reverb system. The signal level at the **EFFECTS OUT** jack is adjusted by the individual channel **EFF./REV.** controls, and the **EFFECTS OUT** master control.

2-3-6. **AUX RETURN LEVEL CONTROL.** Signals patched into the **AUX IN** jack and / or the tape in jacks are sent to the Main buss via the **AUX LEVEL** control. This control determines how much of the **AUX** input signal appears in the main mix.

2-3-7. **GRAPHIC EQUALIZER.** The 9 band graphic equalizer consists of active band pass / band reject filters spaced at octave intervals. The lowest frequency filter is at 63Hz while the highest frequency filter is centered at 16kHz. All others are centered on the frequencies indicated below their sliders. Moving the sliders up or down boosts or cuts the gain at the indicated frequencies. This allows the sound engineer to suppress feedback by compensating for room resonances encountered in live sound reinforcement applications. The EQ controls are accurately scaled in dB to indicate the amount of cut or boost applied at each frequency.

**NOTE:** It is possible for distortion to occur in the Graphic Equalizer if excessive attenuation is used (slider well below center) while also trying to achieve significant level within the bands attenuated.

2-3-8. **PHANTOM POWER Select (Switch and Indicator LED).** Engaging the switch applies 15 volts of phantom power to all the XLR microphone input connectors for powering electret condenser microphones. When the LED is illuminated, this indicates the phantom power is on. The 15 volts used for phantom power will run nearly all condenser microphones.

## 2-4. PATCH BAY.

2-4-1. **MAIN OUT.** Signals from each of the channels are combined with Effects In signals and the Main Reverb signal to form the final main mix. The overall level of the mix is controlled by the **MAIN** level control and this mix appears at the **MAIN OUT** jack. The mix is also normally passed on to the Graphic EQ and to the power amplifier (see Sections 2-4-5 and 2-4-8). Inserting a plug into the **MAIN OUT** jack does not

interrupt the normal signal flow. The jack is useful for recording a live performance. It can also be used for inserting signal processing equipment into the signal path (see Section 4-5), using the **MAIN OUT** as a send, and the **GEQ IN** as a return.

2-4-2. **MONITOR OUT.** Signals present on the Monitor buss are combined in the monitor summing amplifier and sent to the **MONITOR OUT** jack. The signal level present at this output is determined by the **MONITOR LEVEL** control.

2-4-3. **EFFECTS OUT.** Signals present on the Effects/Reverb buss are mixed in the effects/reverb summing amplifier. This mix is sent both to the Reverb driver and to the effects output jack. Thus the mix created by the settings of the **EFF/REV** level controls on each of the preamp channels is present at the **EFFECTS OUT** jack. The overall level at this output is determined by the master mix section **EFF LEVEL** control. This output may be used to drive external effects (echo units, phase shifters, flangers, digital delays, etc.). The return signal from the effect may be patched into the mixer through the **AUX IN** jack, or by way of a preamp channel 1/4" input jack. Use of a preamp channel as a return gives you the ability to shape the frequency response of the signal; however, care must be taken to insure that the **EFF/REV** control on that channel is turned all the way down - otherwise a feedback loop will exist which could cause oscillation and possible damage to speakers. Care must be taken to insure that the amplitude of the return signal is not too great for the preamp channel input. An input pad may be used if needed.

2-4-4. **GRAPHIC OUT.** The output of the Graphic Equalizer is present at the **GRAPHIC OUT** jack; inserting a plug into this jack does not interrupt the normal signal path. The jack is useful for patching more power amplifiers into the system, for post-equalizer recording and for inserting signal processing equipment (limiters, parametric equalizers, etc.) between the equalizer and the power amplifier (see Section 4-5).

2-4-5. **GRAPHIC IN.** The graphic equalizer is prepatched to the main output signal. However, the **GRAPHIC IN** jack allows this "normalized" patch to be defeated; inserting a 1/4" phone plug into the jack disconnects the equalizer from the main signal and instead connects it to any signal carried by the phone plug. This allows the equalizer to be patched to other SR outputs or to other pieces of audio equipment.

2-4-6. **AUX IN.** This input is generally used as a return from an external signal processing device (flanger, phase shifter, etc.). Signals present at this input are routed to the Main buss by way of the **AUX LEVEL** control. In emergencies, it is possible to use the **AUX IN** as a line level preamp channel, although it lacks the preamp channels' equalization, monitor, and effects sends.

2-4-7. **TAPE IN.** Patching the output of a stereo tape deck into the two phono (RCA) jacks produces a monophonic signal in the main mix. This is useful for playing music during breaks in the performance, or for performances where prerecorded music is required. The TAPE IN signal level is controlled by the AUX LEVEL control.

2-4-8. **POWER AMP IN.** Under normal circumstances, the power amplifier receives its input from the Graphic Equalizer. However, by inserting a 1/4" phone plug into the POWER AMP IN jack, the normal signal path is broken and any signal carried by the phone plug becomes the power amplifier's input. This allows the power amplifier to be used independently from the rest of the SR powered mixer. Possible uses of this feature include dedicating the power amp to the monitor system while employing an auxiliary power amplifier for the mains, or using the SR power amp as one of the two power amplifiers in a biamped system (this would require the addition of an external crossover). See Section 4-5.

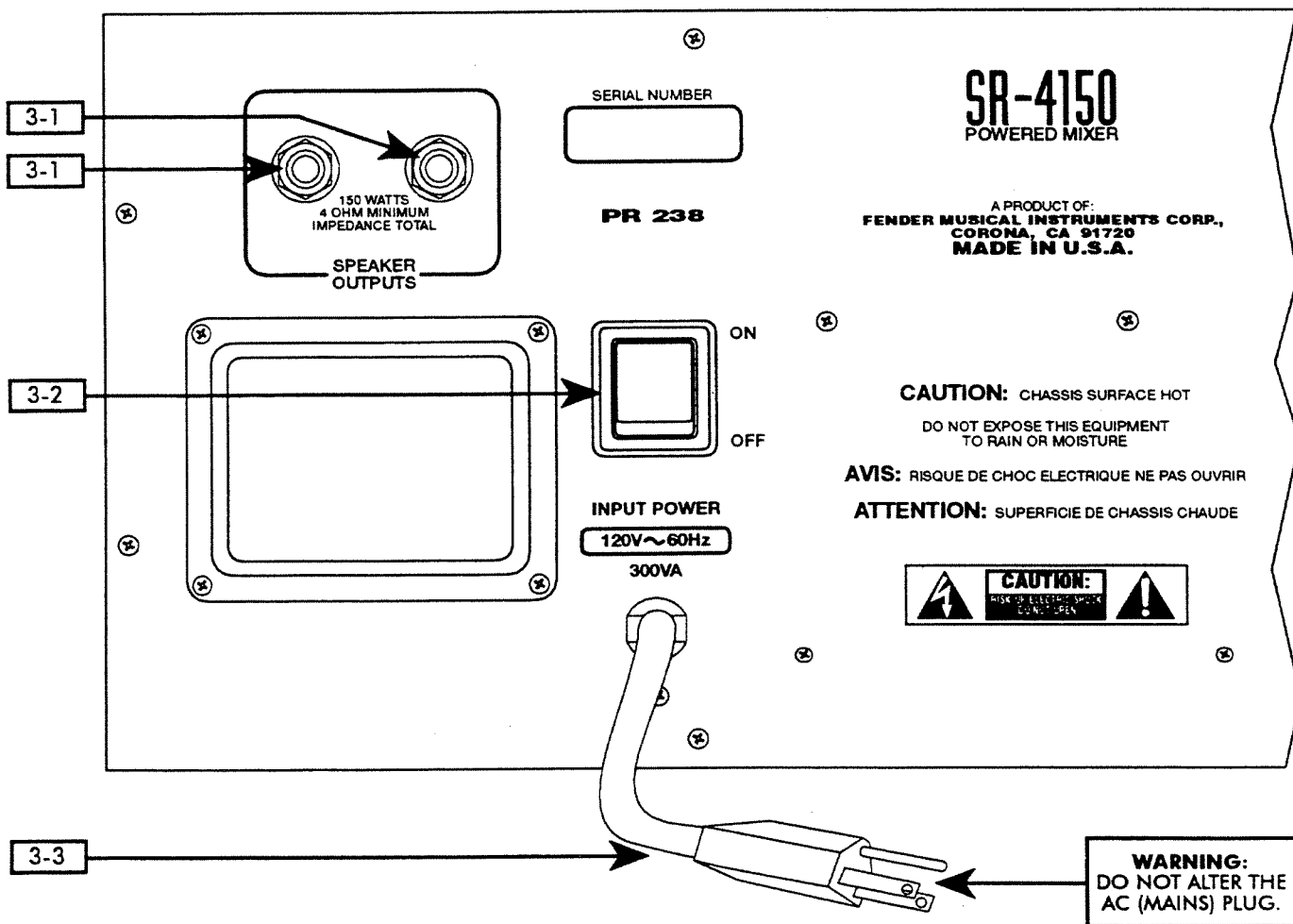
2-5. **LEDS.**

2-5-1. **POWER LED.** The red LED (Light Emitting Diode) is the front panel "power on" indicator.

2-5-2. **PEAK LED.** The yellow LED comes on when excessive signal levels are being sent to the power amp. It illuminates on signal peaks that cause clipping (distortion) with DELTACOMP™ not activated, or for signal peaks that cause DELTACOMP™ to reduce level (DELTACOMP™ active). If the limiter is on for a large percentage of the time, the dynamic range of the system is reduced and the overall sound suffers; for this reason, level controls should be adjusted so that the LIMIT light only flashes on occasional signal peaks.

2-5-3. **PHANTOM POWER LED.** The green LED is the "phantom power on" indicator.

## REAR PANEL CONTROLS



### 3. BACK PANEL

3-1. **SPEAKER OUTPUT JACKS.** These are the speaker outputs for the built-in power amplifier. Do not connect loads with impedances lower than 2 ohms to the SPEAKER OUTPUT, as this may result in amplifier overheating which will cause the SR mixer to eventually self protect, "turning off" for a period of time. (To calculate the speaker impedance, see Section 4-3-2.) In addition, be sure that the speaker cable you use is of adequate gauge; otherwise, power will be lost in the wire instead of being delivered to the speaker, and the damping factor will be impaired (see Section 4-3-2).

3-2. **POWER SWITCH.** AC POWER to the SR powered mixer is turned on and off by a rocker switch located on the back panel. If you have any external signal processing devices patched to the system, turn them on first to avoid pops in the loudspeakers. Also, when you turn on the mixer, make sure that the main fader is down - this eliminates the risk of the system immediately feeding back when it is turned on, and also minimizes turn-on-pops.

3-3. **POWER CORD. WARNING!** Do not remove the grounding prong of the AC plug. To do so risks exposure to potentially lethal voltages and voids the warranty. **DO NOT ALTER THE AC (MAINS) PLUG.**

### 4. SETUP AND OPERATION.

FIGURE 1 illustrates the simplest way to set up your PA system.

4-1. **INITIAL CONTROL SETTINGS.** When you first set up the sound system, initial settings are critical for arriving at a satisfactory mix quickly. Often, to the distress of many sound engineers, the show must begin without a preliminary sound check. The following recommendations should help to alleviate some of the engineer's headaches.

4-1-1 Set the channel high, mid, and low frequency controls to their mid positions, and also set the GRAPHIC EQUALIZER to its mid or flat position. Set the main and monitor MASTER controls to around the 1 o'clock position. Set all other controls to zero.

4-1-2 **LEVEL CONTROL.** Adjust the level controls to the approximate level you desire, with a mix that you feel will be acceptable.

4-1-3. **MONITOR CONTROLS.** Most groups like to hear their voices in the monitors; some also like to hear certain instruments as well (keyboard, acoustic guitar, and so forth). A good initial MONITOR control setting is 5 (straight up). Assuming that the various vocalists use similar miking techniques and sing at similar volumes, the levels appearing in the monitor mix should be fairly matched. Further adjustments can be made as needed.

4-1-4. **CHANNEL EQUALIZATION.** For starters, most vocal, keyboard, and other full range signals are best left flat (controls at 0, or straight up). For signals hav-

ing a great deal of low frequency content, such as drums and bass guitars, the LOW control should initially be backed off slightly (rotated to the left) from the 0 position to reduce boominess. Naturally, all controls should be set to achieve the most pleasing sounds, but the settings listed above should help in achieving good results quickly. In general, extreme settings cause the sound to be unnatural and should be avoided.

4-1-5. **GRAPHIC EQUALIZERS.** Start out with equalizers set "flat" (0 dB). On the SR mixers, the 63 Hz control may be set initially 3 to 6 dB below the center position, since excessive low frequencies rob power from the rest of the system and low-end feedback can damage loudspeakers. Section 4-2 gives hints on making further adjustments to the equalizers.

### 4-2. USING THE GRAPHIC EQUALIZER TO ELIMINATE ACOUSTIC FEEDBACK.

4-2-1. **THE CAUSE OF ACOUSTIC FEEDBACK.** Acoustic feedback in a sound system is the result of coupling between the speakers and microphones. The microphones will always pick up a certain amount of signal from the speakers; how much they pick up depends on the room acoustics, the frequency response of the microphones and speakers, and the mic and speaker placement. If the received signal is amplified enough (in the mixer and power amplifier), the speakers will continue to produce the signal, and the characteristic howl of acoustic feedback will begin. This feedback will occur at the frequency which receives the largest amount of gain from the sound system (including the room). If the signal can be attenuated at that frequency, more gain can be added to the rest of the signal frequencies before feedback occurs. This is the primary role of an equalizer in a sound system.

### 4-2-2. TYPICAL PROCEDURE FOR ROOM EQUALIZATION.

1. Set up your entire sound system the way it will be used, including all auxiliary equipment, and adjust it the way you would normally use it. If feedback occurs during setup, reduce the gain of the mixer with the MAIN and MONITOR level controls. Follow the procedure outlined in the paragraphs below, first for the main system and then for the monitors (assuming you are using an equalizer in your monitor system, which is highly recommended).

2. Set the controls on the graphic equalizers to the "flat" position, indicated as "0 dB" on the panel.

3. Slowly increase the output level (using the appropriate level control) until the sound system is on the threshold of feedback - a ringing sound will occur when you tap on the microphones.

4. Slowly attenuate the Equalizer control which has the greatest effect on reducing the ringing. This will take some trial and error - the first ringing usually



occurs between 1 kHz and 4 kHz. Continue until the ringing has stopped.

5. Again, slowly increase the output level control until the system is on the verge of feeding back. Adjust the equalizer to remove the potential feedback. Continue this procedure until you have achieved sufficient gain for your application or until the equalizer becomes ineffective at removing the ringing. It is best to back off the gain once maximum gain before feedback has been established. Avoid extreme settings or settings which require a large amount of cut in the middle frequency bands, as such settings impair intelligibility.

6. "Fine tune" the equalizer settings as the performance progresses to achieve the best overall sound from the system.

#### 4-3. CORDS AND CABLES.

4-3-1. MICROPHONE CORDS. On the SR mixers, use balanced two-conductor shielded cable for all long runs. Balanced systems are capable of rejecting noise introduced from such sources as cash registers, electric motors and triac-controlled lights. If a balanced cable is connected to an unbalanced output (e.g., a keyboard mixer output) or microphone, use a balancing transformer close to the unbalanced device. This ensures maximum common-mode noise rejection for the entire system.

If you have no choice and must use unbalanced cables, use the shortest cables possible and keep them away from AC power mains, lighting cables and speaker wires. If you want the quietest system possible, you should follow these rules with balanced lines as well.

4-3-2. SPEAKER CABLES. Use two conductor zip cord to connect the amplifier outputs to your speakers. The gauge of the wire is important; wire that is too light in gauge causes a loss in damping factor (the ability of the amplifier to control the motion of the speaker) and also consumes power (the power from the amplifier heats up the wire for your particular situation). To calculate your speaker impedance, use Figure 3.

4-4. INPUT PADS. If input signal levels are too great, the input stage may be overdriven and cause distortion. The solution in such cases is to use an input pad. A 30 dB pad can be made by using a Switchcraft connector (part #S3FM) with the resistor network shown in Figure 4.

4-5. PATCHING. Figures 5 through 8 show possible ways of patching external equipment into the SR mixer. They are by no means the only patches possible. If you want to try a patch that is not illustrated, consult the Block Diagram to determine if your patch is possible. When patching external equipment into the signal chain, best results will be obtained by following these rules:

- Use the highest quality patch cords available and keep them as short as possible.
- Avoid patching a buss output back into its input. An example of this is patching a phase shifter from the EFFECTS OUT and returning it to the input of a channel which has its EFF/REV control turned up. Doing so may result in oscillation (possibly inaudible) that can damage loudspeakers and create distortion.
- Do not use a mic level or instrument level effect (such as an effect intended for guitar) with a line level signal (such as the Main or Graphic EQ output).

#### 5. UPKEEP AND SERVICE

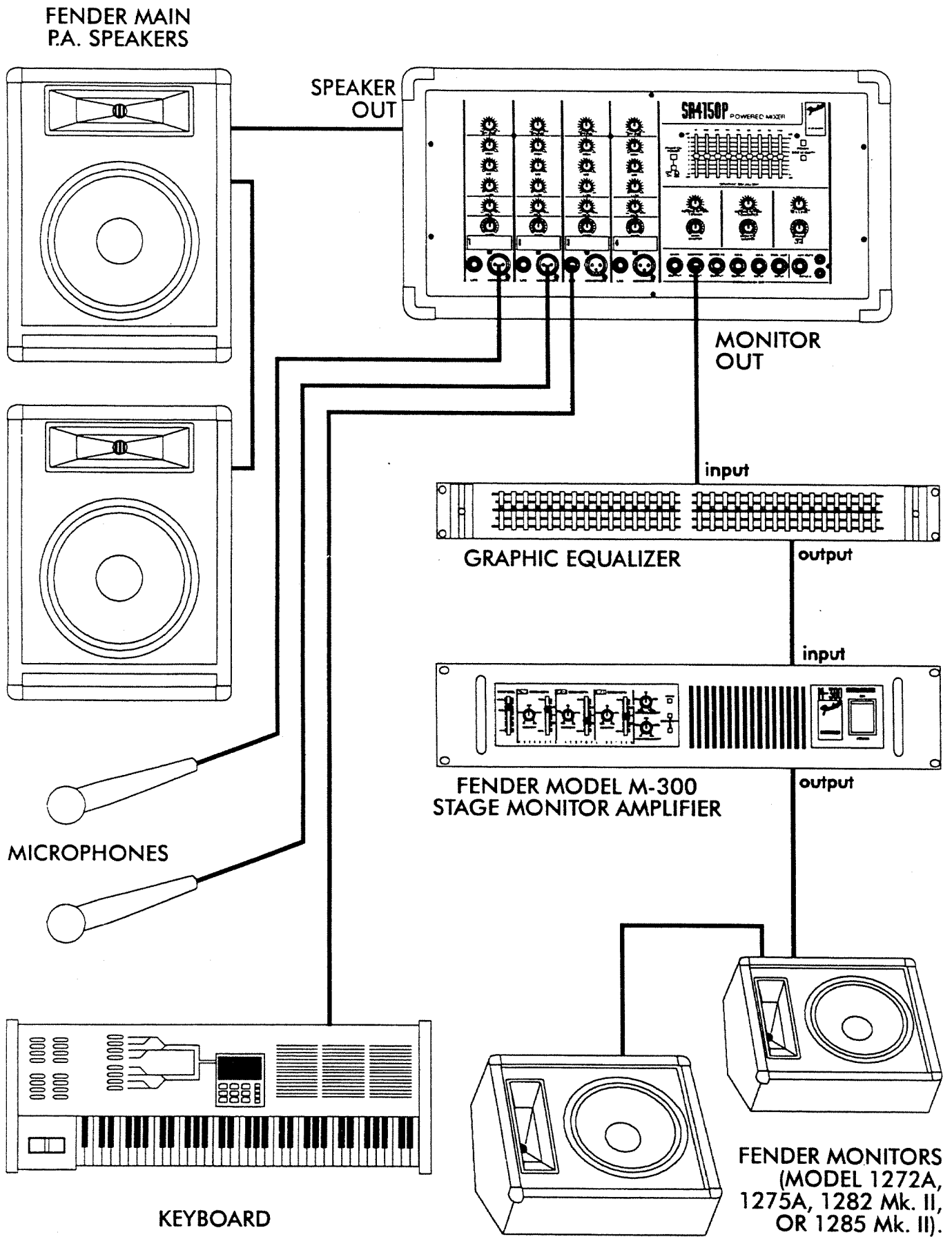
The SR powered mixers have been designed to give years of trouble free service. With a few precautions, you can help to insure its continued reliable service.

- Do not obstruct the air vents on the rear panel.
- Transport the mixer with care.
- Periodically inspect the mixer for damage which may occur during transportation.
- If you leave the mixer set up when you are not using it, protect it from dust with a soft cover.

**DO NOT SET FOOD OR BEVERAGE** on the SR powered mixer - this can not be overemphasized. Spilling a drink can be the quickest way to ruin a potentiometer (fader, level control, EQ control) or switch.

- When using the mixer outdoors, protect it from moisture (rain, sprinklers, beer, etc.)
- Periodically clean the mixer by wiping it with a soft cloth and a small amount of furniture polish.

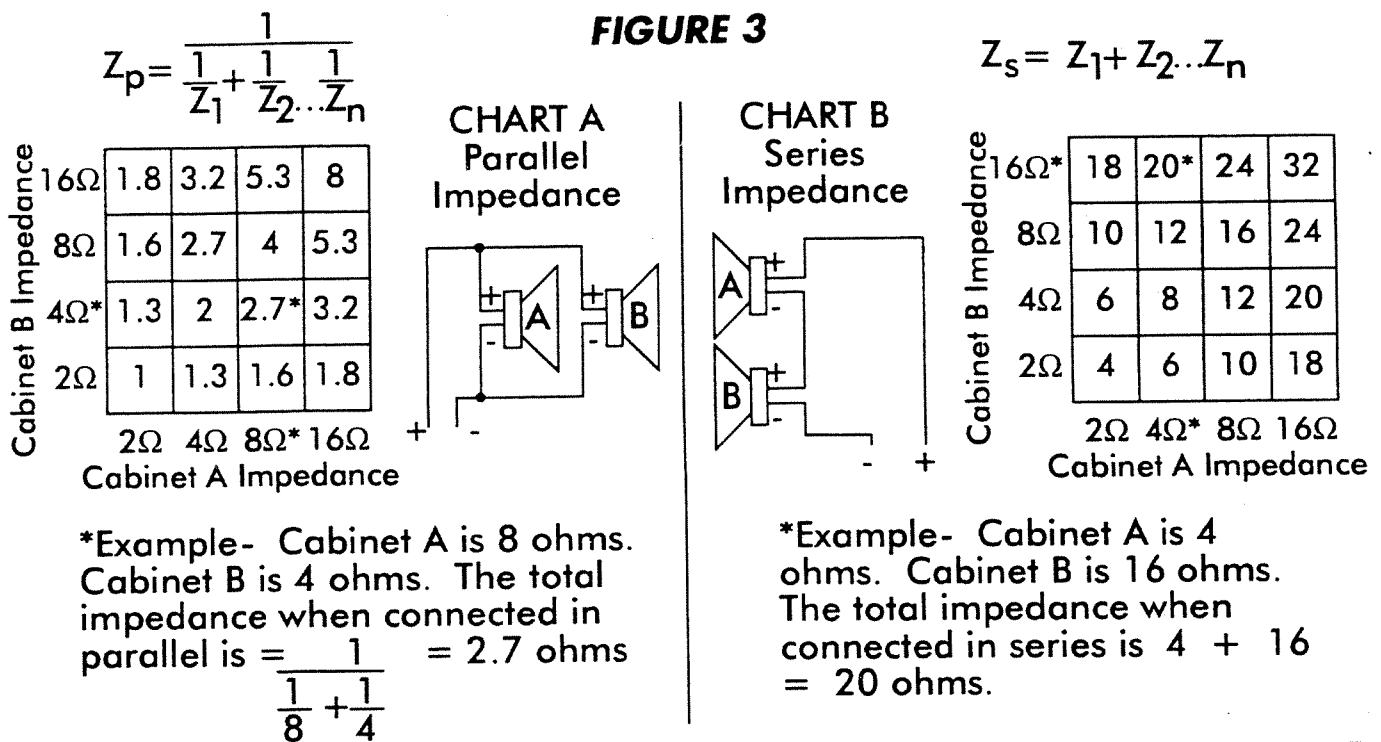
**FIGURE 1**



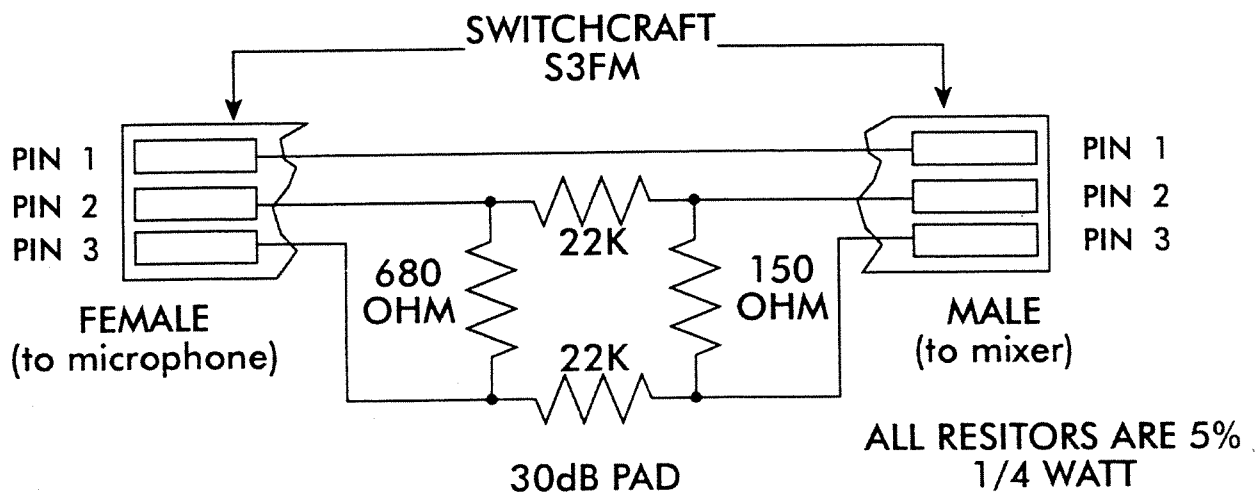
Speaker Wire Length	Speaker Wire Gage			
	2Ω	4Ω	*8Ω	16Ω
100'-UP	8	10	12	14
50'-100'	10	12	14	16
*25'-50'	12	14	*16	18
10'-25'	14	16	18	18
0'-10'	16	18	18	18

**FIGURE 2**

\*Example- The length of speaker wire required is between 25 and 50 feet and the speaker impedance is 8 ohms. The minimum recommended gauge speaker wire is 16 gauge.

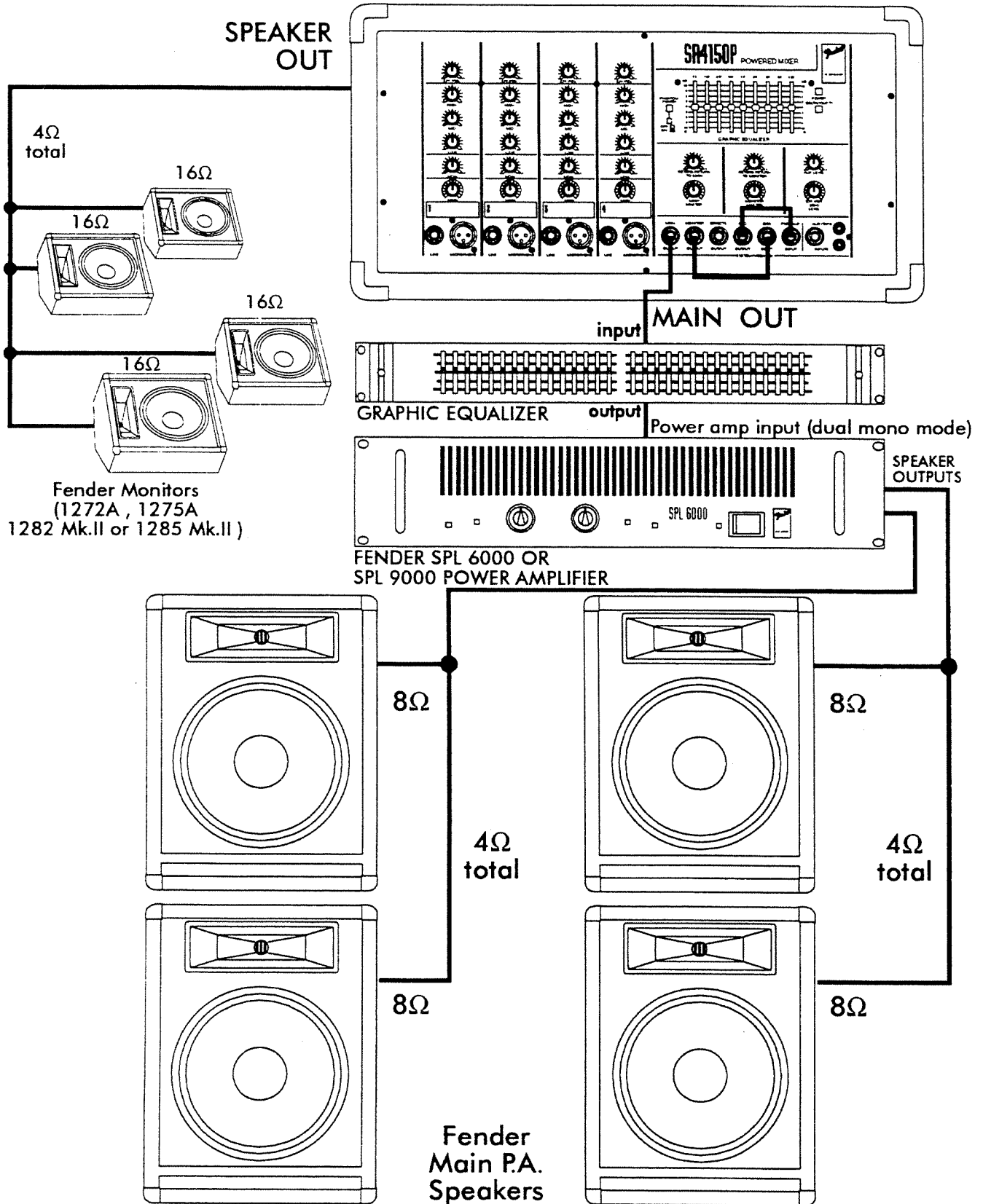


**FIGURE 4**



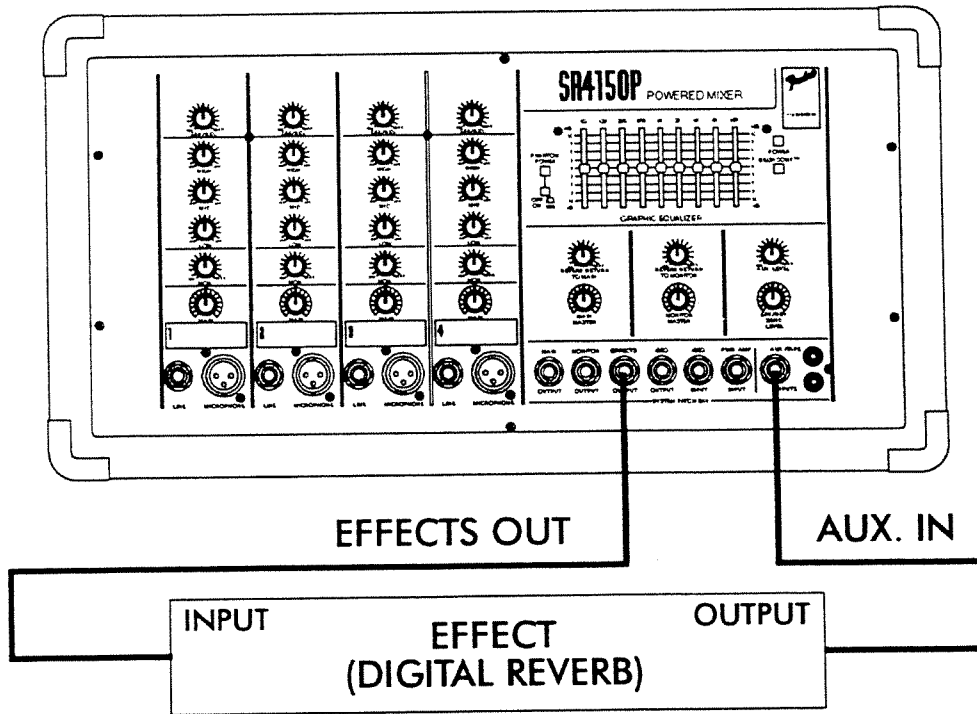
# FIGURE 5

AN ILLUSTRATION USING AN AUXILIARY POWER AMP AND ADDITIONAL SPEAKERS ON THE MAINS FOR MORE POWER, AND THE BUILT IN SR POWER AMP TO POWER UP TO 4 STAGE MONITOR LOUDSPEAKERS. BUILT IN GEQ NOW WORKS ON MONITORS.



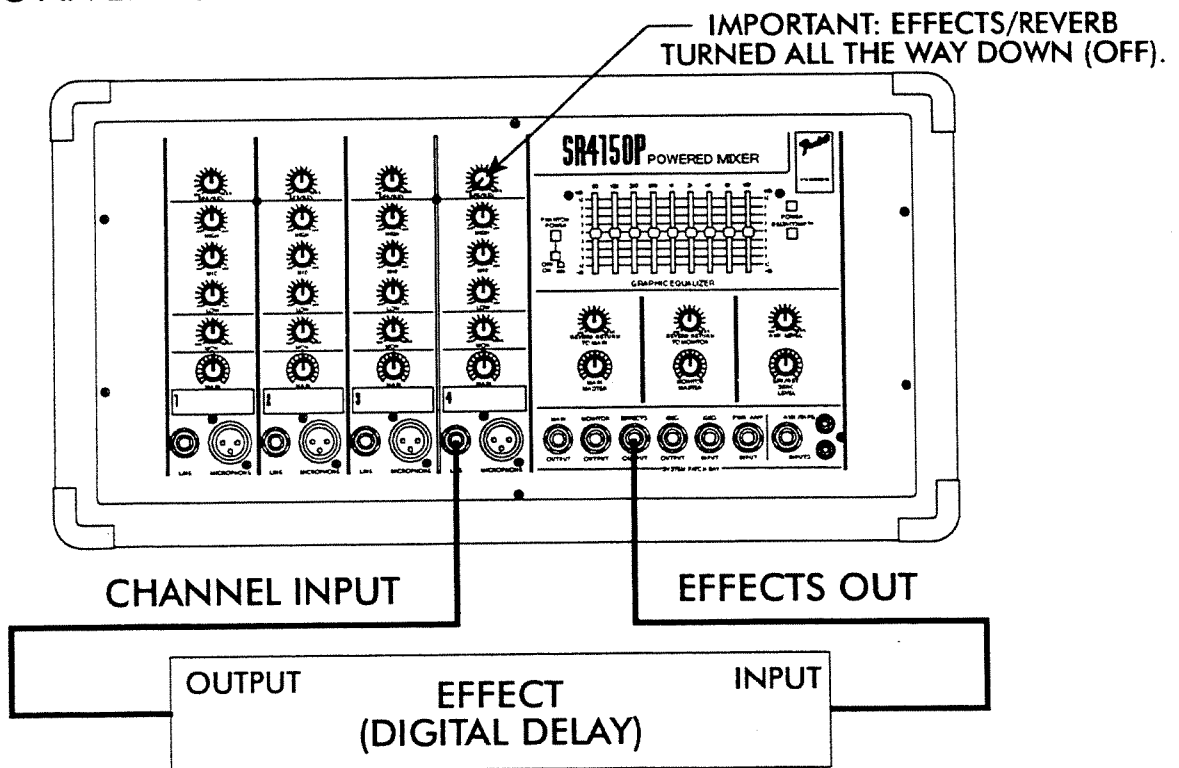
## FIGURE 6

PATCHING AN EFFECT BETWEEN THE EFFECTS OUT AND THE AUX. IN.



## FIGURE 7

PATCHING AN EFFECT BETWEEN THE EFFECTS OUT AND CHANNEL INPUT.



## **SR-6300P / SR-8300P Specifications**

Part Number: 120V Version 071-6300-000 / 071-8300-000  
230V Version 071-6300-060 / 071-8300-060

Type Specification: PR240

Power Specification: 120V Version: 120VAC, 60Hz, 10A Max.  
230V Version: 230VAC, 50Hz, 5.2A Max.

### **POWER AMPLIFICATION SECTION:**

Power Output: 300 Watts

Rated Load Impedance: 2 Ohms

Distortion at 300 Watts: Less than .2% @ 1KHz into 2 Ohms

Input Sensitivity: 1.06 Volts R.M.S.

Input Impedance: 22K Ohms

DELTA COMP™ Range: 20dB

### **PRE-AMPLIFIER SECTION:**

LOW-Z Input Impedance: 1.82K Ohms

HI-Z Input Impedance: 18.2K Ohms

HI-Z Input Sensitivity for 300W:  
(MAIN MASTER and Channel  
MAIN at maximum, all tone  
controls and GEQ at "0"  
detent, power amp at 300  
Watts, 4 Ohms).

Channel Tone Controls: LOW +/- 15 dB at 100 Hz  
MID +/- 15 dB at 750 Hz  
HIGH +/- 15 dB at 10 KHz

Graphic Equalizer: +/- 12dB at 63, 125, 250, 500, 1K, 2K, 4K, 8K and  
16K Hz.

### **PHYSICAL SPECIFICATIONS:**

	SR6300P	SR8300P
Height:	10-7/16 Inches ( 26.5 cm )	Height: 10-7/16 Inches ( 26.5 cm )
Width:	21-5/8 Inches ( 54.9 cm )	Width: 25-5/8 Inches ( 65.1 cm )
Depth:	12 Inches ( 30.5 cm )	Depth: 12 Inches ( 30.5 cm )
Weight:	38.5 Lbs. ( 17.5 Kg )	Weight: 40.5Lbs. ( 18.4 Kg )

## **SR-6520P / SR-8520P Specifications**

Part Number: 120V Version 071-6521-100 / 071-8521-100  
230V Version 071-6521-160 / 071-8521-160

Type Specification: SR-6520P: PR179  
SR-8520P: PR189

Power Specification: 120V Version: 120VAC, 60Hz, 10A Max.  
230V Version: 230VAC, 50Hz, 5.2A Max.

### **POWER AMPLIFICATION SECTION:**

Power Output: 520 Watts

Rated Load Impedance: 2 Ohms

Distortion at 520 Watts: Less than .2% @ 1KHz into 2 Ohms

Input Sensitivity: 1.28 Volts R.M.S.

Input Impedance: 22K Ohms

DELTA COMP™ Range: 20dB

### **PRE-AMPLIFIER SECTION:**

LOW-Z Input Impedance: 1.82K Ohms

HI-Z Input Impedance: 18.2K Ohms

HI-Z Input Sensitivity for 520W:  
(MAIN MASTER and Channel  
MAIN at maximum, all tone  
controls and GEQ at "0"  
detent, power amp at 520  
Watts, 4 Ohms).

55mV R.M.S.

Channel Tone Controls: LOW +/- 15 dB at 100 Hz  
MID +/- 15 dB at 750 Hz  
HIGH +/- 15 dB at 10 KHz

Graphic Equalizer: +/- 12dB at 63, 125, 250, 500, 1K, 2K, 4K, 8K and  
16K Hz.

### **PHYSICAL SPECIFICATIONS:**

	SR6520P	SR8520P
Height:	10-7/16 Inches ( 26.5 cm )	Height: 10-7/16 Inches ( 26.5 cm )
Width:	21-5/8 Inches ( 54.9 cm )	Width: 25-5/8 Inches ( 65.1 cm )
Depth:	12 Inches ( 30.5 cm )	Depth: 12 Inches ( 30.5 cm )
Weight:	38.5 Lbs. ( 17.5 Kg )	Weight: 40.5Lbs. ( 18.4 Kg )

## **SR-4150P Specifications**

Part Number: 120V Version 071-4100-000  
230V Version 071-4100-060

Type Specification: PR238

Power Specification: 120V Version: 120VAC, 60Hz, 2.5A Max.  
230V Version: 230VAC, 50Hz, 1.3A Max.

### **POWER AMPLIFICATION SECTION:**

Power Output: 150 Watts

Rated Load Impedance: 4 Ohms

Distortion at 150 Watts: Less than .5% @ 1KHz into 4 Ohms

Input Sensitivity: 1.00 Volts R.M.S.

Input Impedance: 22K Ohms

DELTA COMP™ Range: 20dB

### **PRE-AMPLIFIER SECTION:**

LOW-Z Input Impedance: 1.82K Ohms

HI-Z Input Impedance: 18.2K Ohms

HI-Z Input Sensitivity for 150W: 55mV R.M.S.

(MAIN MASTER and Channel  
MAIN at maximum, all tone  
controls and GEQ at "0"  
detent, power amp at 150  
Watts, 4 Ohms).

Channel Tone Controls: LOW +/- 15 dB at 100 Hz

MID +/- 15 dB at 750 Hz

HIGH +/- 15 dB at 10 KHz

Graphic Equalizer: +/- 12dB at 63, 125, 250, 500, 1K, 2K, 4K, 8K and  
16K Hz.

### **PHYSICAL SPECIFICATIONS:**

Height:	10-7/16 Inches	( 26.5 cm )
Width:	19-3/8 Inches	( 49.2 cm )
Depth:	12 Inches	( 30.5 cm )
Weight:	27 Lbs.	( 12.3 Kg )

A Product of:  
Fender Musical Instruments Corp.,  
Corona, CA 91720