

OWNERS MANUAL

Fender[®]
MUSICAL INSTRUMENTS
1300 E. Valencia, Fullerton, California 92631

FUZZ WAH PEDAL

Fender®

FUZZ WAH PEDAL

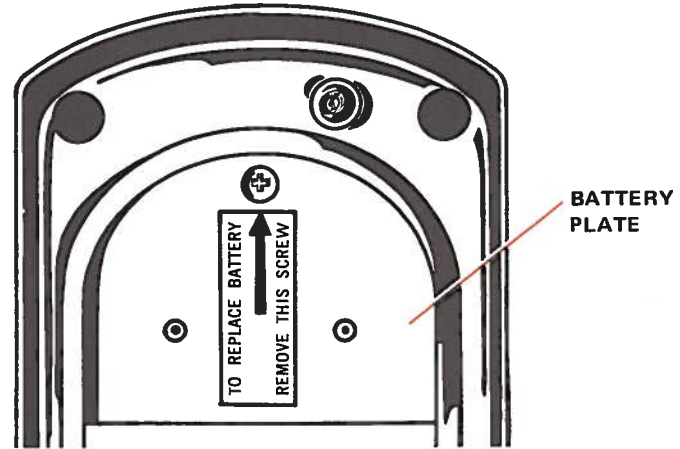

FENDER FUZZ WAH PEDAL

The versatile Fender Fuzz Wah pedal is a dual action device which can produce a wide range of "fuzz" and "wah" effects. These are activated with a tap of the foot on either of the two clearly labeled switches and can be used separately or simultaneously. When the special effects are not in use the pedal controls only volume.

The "fuzz" effect is activated by pressing the "fuzz" switch. The "wah" effect is produced by pressing the "wah" switch and using an up-and-down motion of the pedal. Side-to-side motion of the pedal regulates volume.

BATTERY

The Fender Fuzz Wah pedal requires an 8.4 volt mercury battery which is activated only when a cord is plugged into the "instrument" jack on the pedal. For maximum battery life disconnect the cord from the instrument jack when the pedal is not in use.

To install the battery, remove one Phillips head screw from the underside of the pedal at the toe end, as shown, and remove the battery plate. Although an 8.4 volt mercury battery is recommended, a standard 9 volt transistor battery will work satisfactorily in an emergency. Be sure that the battery is securely attached to the snaps before replacing the battery plate and screw.

PEDAL HOOKUP

Two guitar cords are required. Plug your instrument into the "instrument" jack on the pedal, and connect the "amplifier" jack on the pedal to the input jack on the amplifier.

On a Fender two-channel amplifier, it is possible to control "normal" instrument amplification on one channel and "fuzz" and "wah" on the other channel. The hookup is as follows: Number "1" input of the amplifier "normal" channel is connected to your instrument "normal" channel is connected to the "instrument" jack on the pedal. Number "1" input of the amplifier "vibrato" channel is connected to the "amplifier" jack on the pedal. "Normal" instrument amplification is now controlled from the amplifier "normal" channel and "fuzz" and "wah" are controlled from the amplifier "vibrato" channel.

WARRANTY REGISTRATION CARD FUZZ WAH PEDAL

The Fender warranty becomes effective only if this card is returned to Fender Musical Instruments within ten (10) days after purchase. It should be filled out, signed, detached, and mailed immediately. Upon receipt of this card, you will be mailed your Fender-owner identification card.

Purchase date _____ Serial No. _____
Owner's name _____ Age _____ Sex _____
Address _____ City _____ State _____
Zip _____ Purchased from _____ State _____
Owner's Signature _____
I am: professional semi-professional amateur
I bought a Fender because of:
Personal preference Advertising Reputation Recommended Other
Education: Years _____
List two of your favorite magazines _____

WARRANTY

Fender Musical Instruments warrants this product to be free from defects in materials and workmanship for a period of one year from date of purchase. The warranty herein extends only to the original purchaser at retail of a new product. This warranty shall not apply to products purchased from anyone other than an authorized Fender dealer, or to products which have been subject to alteration, misuse, accident, neglect (such as extremes of temperature and/or moisture), or to wear resulting from normal usage.

The warranty herein becomes effective upon receipt of the completed attached owner registration card within ten (10) days after date of purchase. Upon its receipt the owner will be sent a personalized Fender warranty identification card. Presentation of the card within the warranty period will entitle the owner to receive authorized service and repair from any authorized Fender dealer. Such service and repair shall include all labor and materials necessary to make the repairs and replacements covered under the terms of this warranty.

If the product must be returned to the factory service center for repair, it must be accompanied by an authorized Fender dealer's written direction to such effect and a Fender shipping label. Transportation charges to and from the service center shall be borne by the owner unless otherwise specified by law. This warranty is expressly in lieu of all other agreements and warranties, express or implied, except as may be otherwise required by law.



PLACE
STAMP
HERE

FENDER MUSICAL INSTRUMENTS
1300 E. Valencia
Fullerton, California 92631