

**Fender<sup>®</sup>**

THE SOUND THAT CREATES LEGENDS

**Performer**  
1000

TYPE: PR 209

**Owner's Manual**

P/N 040268

# Performer 1000 Sound Settings

## Basic Strat Set Up / Any Pickup Combination

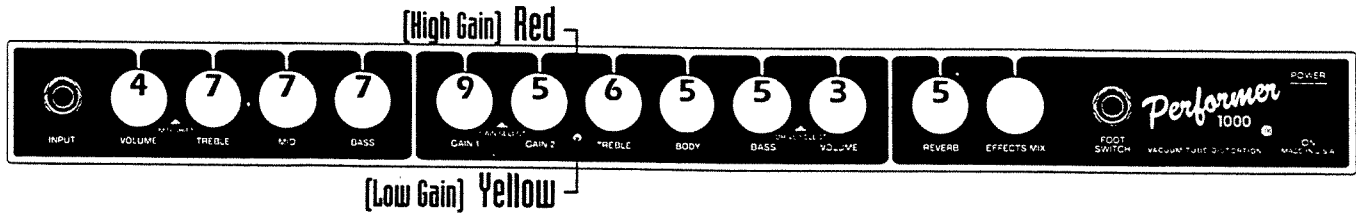

## Brown Humbucker / Bridge Position

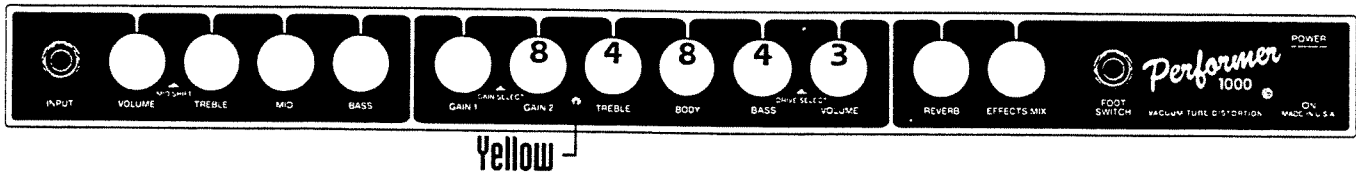

## Edge to Sledge / Humbucker in Bridge

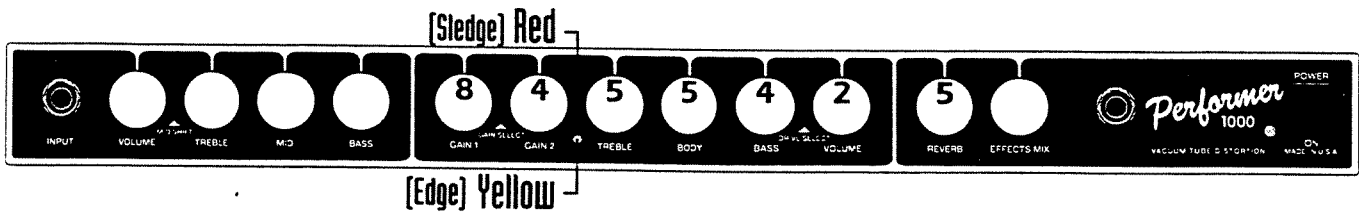

## Strat Aggression / Bridge Pickup

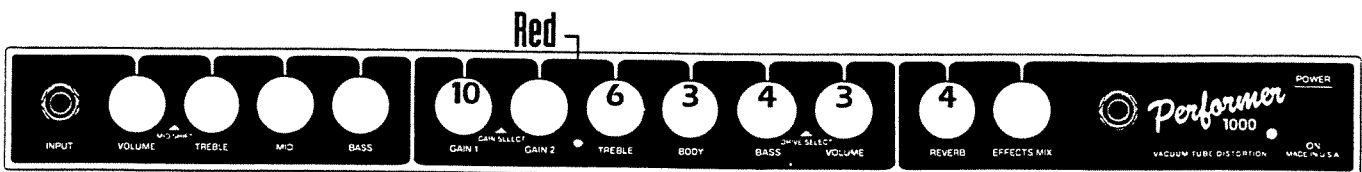

# Performer 1000 Owner's Manual

The Fender PERFORMER 1000 is a radical combination of aggressive Vacuum Tube Distortion sounds and time tested Signature Fender Clean sounds packaged together in a unique "Hybrid" configuration, bringing together the best of Tube and Solid State technology.

The PERFORMER 1000 Normal channel features the standard complement of Volume, Treble, Mid, and Bass controls with the addition of a "Mid Shift" button for ultra clean sounds. The Drive channel utilizes a single **12AX7 Vacuum Tube** for distortion characteristics and offers a unique "Dual Gain" feature allowing the player to switch between two independently voiced Tube Distortion settings. The Drive channel controls include Gain 1, Gain 2, Treble, Body, Bass, and Volume. The almost unlimited combinations of Gain and Tone controls will vary your sound from a sweet, singing sustain to the most gnarly growl imaginable.

The PERFORMER 1000 features a detachable three button footswitch for Channel select, Gain select, and Reverb On/Off. Standard 1/4 inch phone jacks are used for ease of connection or extension of the footswitch to remote pedal boards. The "three way" variable EFFECTS LOOP allows the use of virtually any effects device, from simple stomp boxes to sophisticated rack equipment, without annoying input distortion. The EFFECTS MIX control is used for blending the effect (wet) sound with the normal (dry) guitar sound. Depending on the effects device used, the EFFECTS MIX control when set to "10", will produce the "wet" sound only.

Last, but definitely not least, the PERFORMER 1000 packs a 100 watt power amp based on a radically underdamped design that interacts with the speaker in much the same way as a tube amplifier, producing sparkle and punch with an increase in apparent loudness and power that defies comparison to other similarly rated units. Also included is a sophisticated, transparent protection scheme designed to completely prevent amplifier failure due to bad speaker cords or incorrectly connected speaker jacks. This amp is VERY LOUD and can reliably put it out night after night.

The selection of a Fender amplifier will reward you with years of quality performance and a wide range of musical sounds. This manual is designed to familiarize you with the equipment and to acquaint you with its many features. Please read it carefully so you will benefit from all the features as soon as you start using the amplifier.

The built in quality of a Fender amplifier is the result of over four decades of dedication in the combined skills of research and development by our engineers and musicians.

That is why we proudly say...**FENDER, The Sound That Creates Legends.**

**WARNING: TO PREVENT FIRE OR SHOCK HAZARD, DO NOT EXPOSE THIS UNIT TO RAIN OR MOISTURE**

# Performer 1000 Front Panel Functions

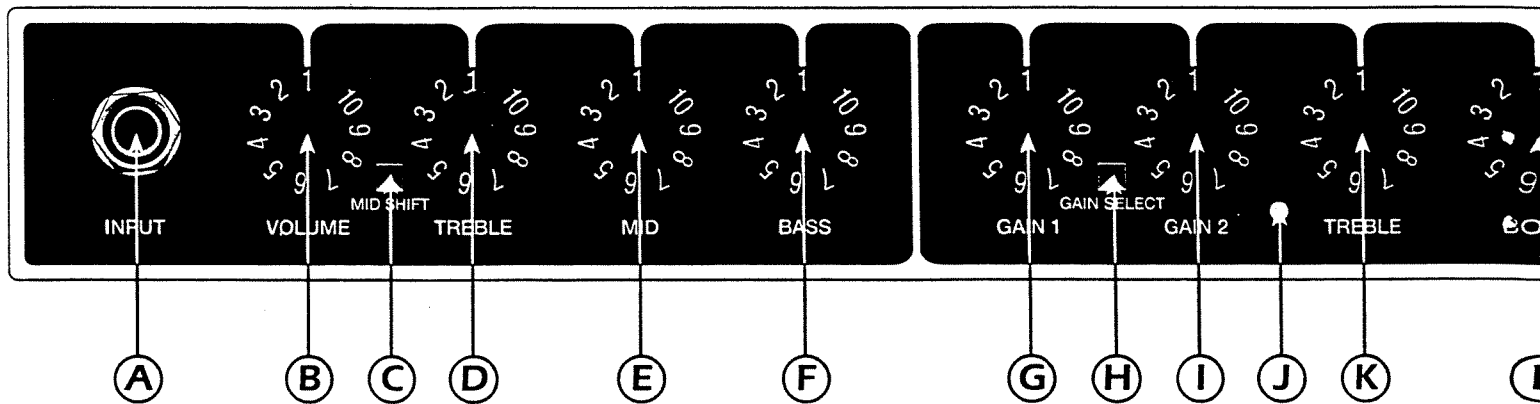

A. **INPUT** – A high impedance, high sensitivity plug-in connection for instruments.

B. **VOLUME** – Adjusts the overall volume of the NORMAL channel.

C. **MID SHIFT** – When this button is depressed, it moves the frequency center of the NORMAL channel MID control up one octave. The tonal effect is a slight increase in bass response and a slight reduction of upper mids for a cleaner sound.

D. **TREBLE** – Adjusts the amount of high frequency boost or cut in the NORMAL channel.

E. **MID** – Adjusts the amount of mid frequency boost or cut in the NORMAL channel.

F. **BASS** – Adjusts the amount of low frequency boost or cut in the NORMAL channel.

G. **GAIN 1** – Adjusts the amount of distortion in the RED DRIVE channel. Lower settings provide a gradual compression distortion, while higher settings provide more sustain. This control works

in conjunction with the DRIVE channel VOLUME control (item O) to set the overall volume of the RED channel.

H. **GAIN SELECT** – This switch selects between the RED and the YELLOW channels. The IN position selects the RED channel, the OUT position selects the YELLOW channel.

I. **GAIN 2** – Adjusts the amount of distortion in the YELLOW DRIVE channel. Lower settings provide a gradual compression distortion, while higher settings provide more sustain. This control works in conjunction with the DRIVE channel VOLUME control (item O) to set the overall volume of the YELLOW channel.

J. **DRIVE CHANNEL INDICATORS** – The RED LED is illuminated while the RED channel is in use. The YELLOW LED is illuminated while the YELLOW channel is in use.

K. **TREBLE** – Adjusts the amount of high frequency boost or cut in the DRIVE channel. This control is post distortion and is useful in adjusting the distortion from smooth to brash.

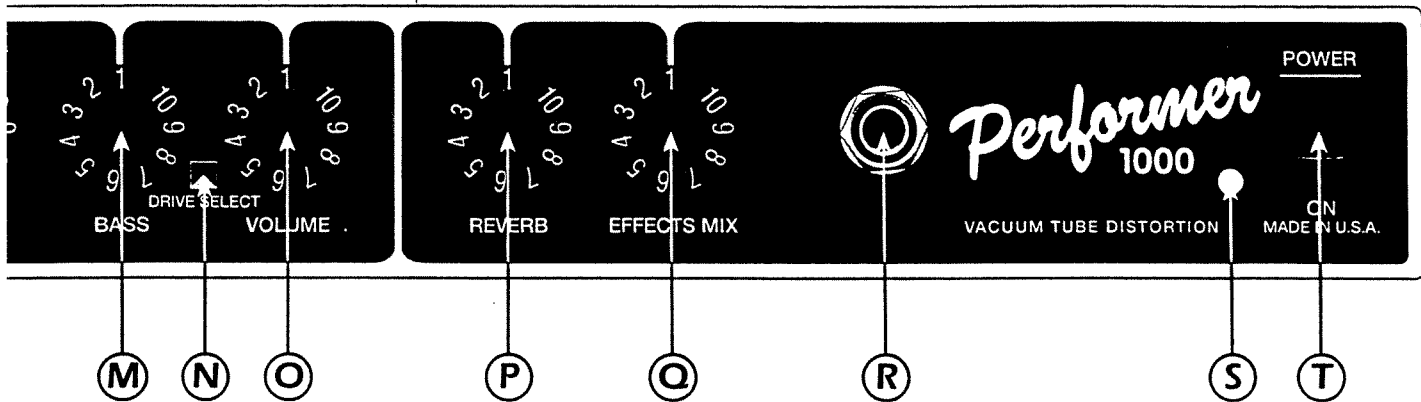

- L. **BODY** – Adjusts the overall tone quality of the DRIVE channel. High BODY settings will emphasize mid frequencies. A lower setting will notch the midrange to produce the “crunch” sound characteristic in most heavy metal music.
- M. **BASS** – Adjusts the amount of low frequency boost or cut in the DRIVE channel. This control is post distortion and is useful for adjusting the amount of “thump” or “chunk” produced by the DRIVE channel.
- N. **DRIVE SELECT** – When this button is depressed, the amp switches from the NORMAL channel to one of the DRIVE channels, depending on the GAIN SELECT switch (item H).
- O. **VOLUME** – Adjusts the overall volume of the DRIVE channel.
- P. **REVERB** – Adjusts the amount of reverb present in both DRIVE channels and the NORMAL channel.
- Q. **EFFECTS MIX** – Adjusts the amount of audible effects (wet) signal while using the variable

- EFFECTS LOOP (located on the rear panel). Lower EFFECTS MIX settings will produce less “wet” signal. Depending on the effects device used, the EFFECTS MIX control, when set to “10”, will produce the “wet” signal only. With nothing plugged into the RETURN (item Z) jack, the control is disconnected.
- R. **FOOTSWITCH**– Plug-in connection for a remote footswitch to switch between the NORMAL and DRIVE channels, RED and YELLOW channels, and to turn the REVERB on and off. NOTE: Any good quality patch cord will work with the remote footswitch; however, a speaker grade cord is preferable to a coax guitar cord when it's available. Using the footswitch overrides the front panel select buttons.
- S. **POWER INDICATOR** – This LED is illuminated when the power is ON.
- T. **POWER SWITCH** – Turns the AC power ON and OFF. When the switch is in the OFF position the amplifier is completely shut down.

# Performer 1000 Rear Panel Functions

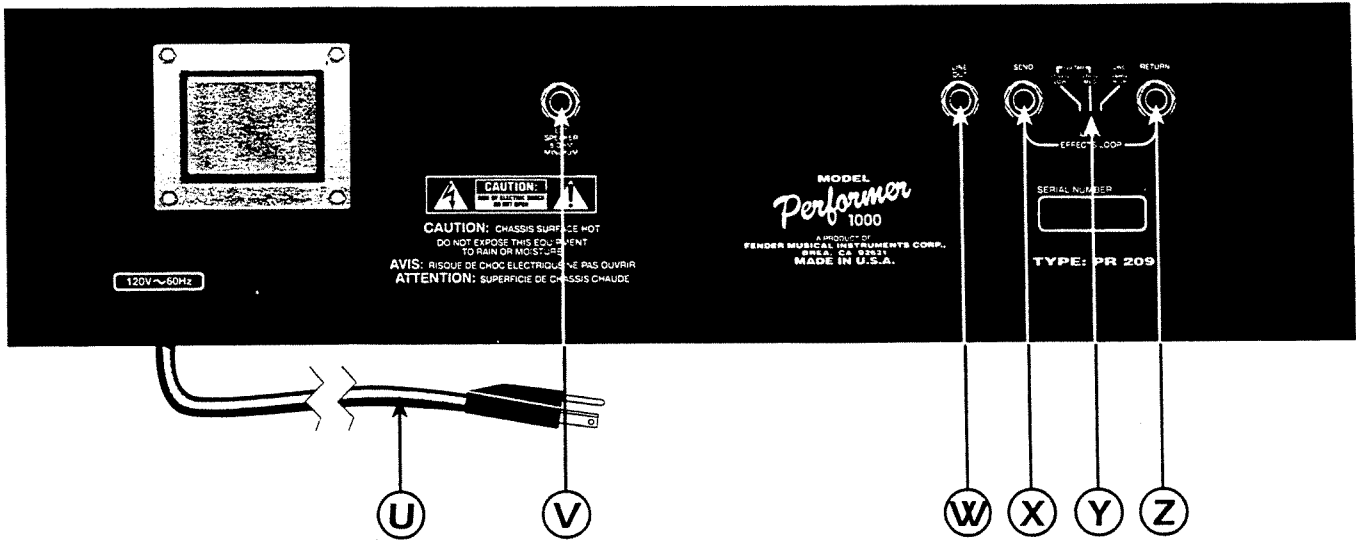

**U. LINE CORD**— The PERFORMER 1000 is equipped with a grounding type supply cord to reduce the possibility of shock hazard. Be sure to connect it to a grounded AC receptacle. **DO NOT ALTER THE AC PLUG.**

**V. 8-OHM EXT SPEAKER JACK** — (On Combo & Head models) Plug-in connection on rear panel for 8 ohm speakers only.

**4-OHM EXT SPEAKER JACK** — (On Head models only) Plug-in connection on rear panel for a single 4 ohm speaker or a second 8 ohm speaker enclosure. The combined minimum impedance for all speaker enclosures should be 4 ohms (i.e. two 8 ohm enclosures in parallel).

On 230V units, the external speaker jacks are marked with the IEC Dangerous Voltage Symbol.

**W. LINE OUT** — This jack provides an output signal taken directly off the amplifier output and speaker and is used for direct connection to recording and sound reinforcement equipment. Using a stereo cord in this jack will provide a quasi-balanced signal. A mono cord will provide an unbalanced signal.

**X. SEND** — This unbalanced jack provides an output signal from the preamp, pre-reverb. It is used to patch into effects.

**Y. LEVEL SWITCH** — This switch directly effects the SEND (item X) jack by boosting or attenuating the signal sent to the effects. External rack effects usually require -7dB or +4dB settings. Effects pedals usually require a -16dB setting.

**Z. RETURN** — This jack provides a return from effects gear, Pre-reverb. Plugging into this jack activates the EFFECTS MIX control (item Q).

## Troubleshooter's checklist

- Is the power cord properly plugged into an electrical outlet?
- Is there power at the outlet?
- Is the speaker properly connected to the amplifier?
- Are all the control knobs turned above four?
- Is the volume control on the instrument turned up?
- Is the instrument properly plugged into the amplifier? (Eliminate all effects and try another guitar cord.)

If, after checking all of the above, the system is still not working correctly, consult your Fender Service Dealer.

# Performer 1000 Block Diagram

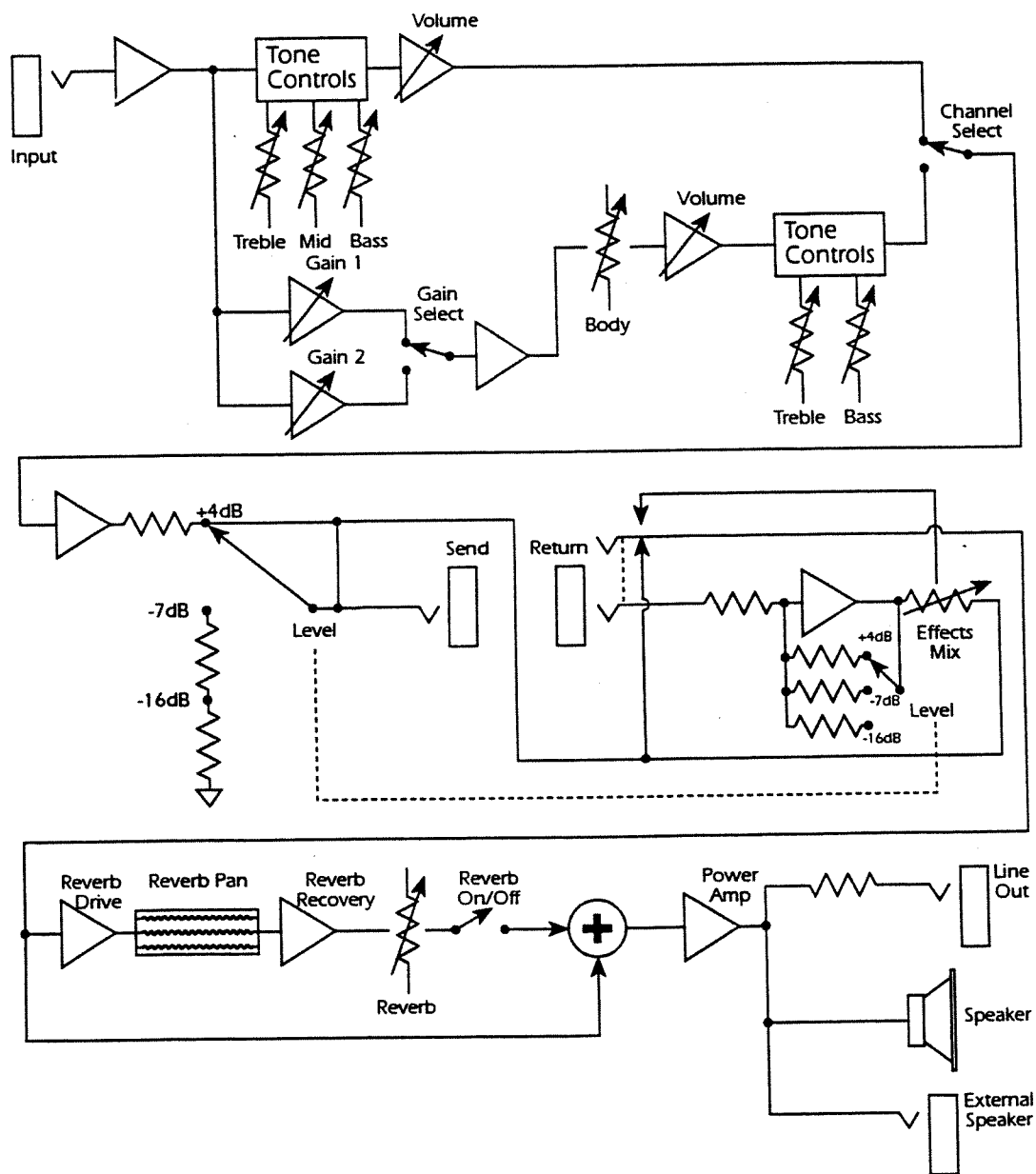

A PRODUCT OF:  
**FENDER MUSICAL INSTRUMENTS CORP.,**  
 BREA, CA 92621