

**Fender<sup>®</sup>**

THE SOUND THAT CREATES LEGENDS

**BXR 25**

**Owner's Manual**

P/N 047999

## BXR 25

The Fender **BXR 25** amplifier is the most recent effort in state-of-the-art bass amplifier technology. The Fender design team developed the **BXR 25** with the assistance from some of today's best musicians. It represents years of decisions concerning performance, features, and specifications. The features included in the **BXR 25** make it a viable and tough competitor, whether meeting the demands of a serious practice session, or just jammin'!

The preamp section of the BXR 25 features two inputs of differing sensitivity, that allow connection of a variety of signal sources and levels. Built-in emphasis circuitry is included to provide enhancement of the extreme low and high ends of the frequency spectrum. Wide range active "HIGH", "MID", and "LOW" controls allow further response tailoring of the high, mid, and low frequency areas of the sounds you and your instrument produce. The rugged 25 Watt power amplifier was designed to give years of reliable service under all conditions and is equipped with a unique implementation of our exclusive DELTACOMP™ adaptive compression system. When DELTACOMP™ engages, it is practically impossible to cause the power amplifier to clip (distort). With DELTACOMP™, apparent compressor release time is kept short, yet waveform distortion is kept to a minimum at low frequencies.

A number of professional features have been added to the BXR 25 like PREAMP OUT & POWER AMP IN jacks which can be used as an Effects Loop. The PREAMP OUT is connected to the input of your effect (digital delay or other effects device) and the output from the effect is returned to the POWER AMP IN. The PREAMP OUT can also be used to connect your BXR 25 directly to a recording console or sound reinforcement mixer. The HEADPHONE jack automatically mutes the speaker in addition to driving Stereo or Mono headphones.

The selection of a Fender amplifier will reward you with years of quality music in a wide range of sonic possibilities. This manual is designed to familiarize you with the features and functions of your BXR 25 amplifier. Read this manual carefully so you will benefit from these features as soon as you start using your new Fender amplifier.

The built-in quality of a Fender amplifier is the result of over four decades of dedication in the combined skills of the Fender design team.

That's why we proudly say .....**FENDER, The Sound That Creates Legends.**

**WARNING: TO PREVENT FIRE OR SHOCK HAZARD, DO NOT EXPOSE UNIT TO RAIN OR MOISTURE.**

## BXR 25 FRONT PANEL FUNCTIONS

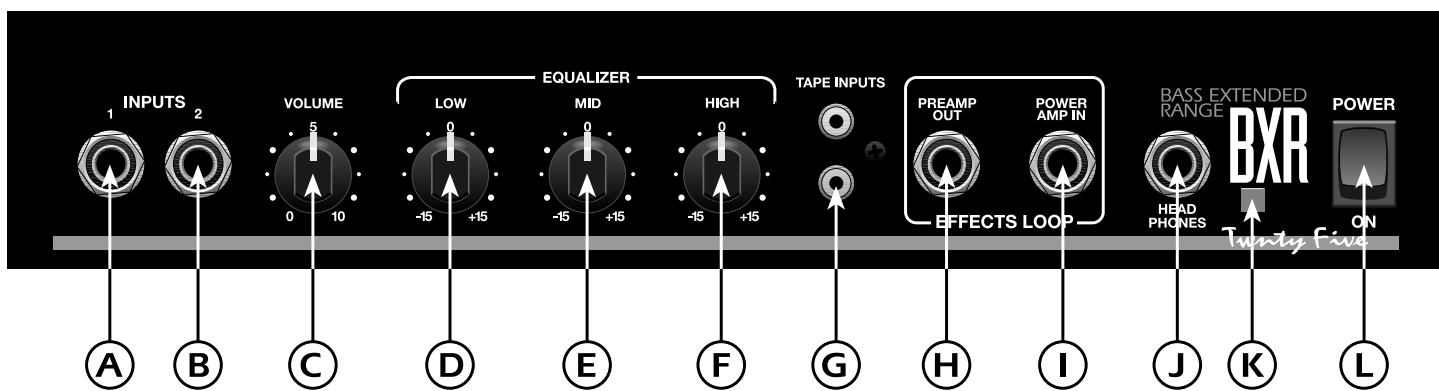

The front panel contains all items necessary for system operation and observation. Please read this section of the manual carefully to make sure you understand all the operational features of your new FENDER BXR 25 amplifier.

**A. Input 1:** High gain

**B. Input 2:** Low gain

The high gain input (INPUT 1 ) should be used for most instruments. This input can handle as much as 3.5 volts R.M.S., while the low gain input (INPUT 2) accepts 7 volts R.M.S. without audible distortion. For both cases, this is greater than any active bass with a 9 volt battery can produce. If you are using a bass with dual 9 volt batteries or a "hot" passive bass, it might be wise to try INPUT 2. For the rare case where two players want to use one amplifier or where two instruments are to be used during the performance, both inputs may be used.

**C. VOLUME:** This control sets the gain of the preamp and serves as an adjustment for the "loudness" of the amplifier.

**D. LOW:** adjusts the low frequency part of the spectrum, the area where the "deep" fundamentals reside.

**E. MID:** adjusts the mid frequency part of the spectrum. Turning the mid down will cause the sound to become "TIGHT" or more "PUNCHY."

**F. HIGH:** adjusts the high frequency part of the spectrum. Turning the HIGH up will cause the sound to become "BRIGHT" or more "CRISP".

**G. TAPE INPUTS:** Plug-in connection for any line level (500mV) stereo or mono signal. This signal is mixed into the power amp along with the instrument signal from the preamp. It has fixed gain and is unaffected by any of the front panel controls; however, the signal will be affected by any device inserted between the preamp output and the power amp input. It is useful for patching in a CD, tape player, rhythm machine or other signal source to be used as accompaniment for practice or performance. The output level control of the external signal source is used to control its own volume while the front panel volume control is used for the instrument in order to obtain a balance.

**H. PREAMP OUT:** This jack provides an unbalanced output signal from the preamp. This output can be used in conjunction with the POWER AMP IN as a patch point for external mono effects devices.

**I. POWER AMP IN:** This unbalanced jack inputs signal directly to the power amp section. It automatically disconnects the preamp circuitry when used. This is useful when using the patch point option or when using the BXR 25 as a slave amplifier for an external signal source.

**J. HEADPHONES:** This jack provides an output to standard stereo or mono headphones for private listening. **NOTE:** Use of this jack automatically disables the main speaker. **CAUTION:** Prolonged listening at high levels may be hazardous to your hearing!

**K. POWER INDICATOR:** When this LED is illuminated, the BXR 25 is receiving power.

**L. POWER:** Turns the BXR 25 on or off.

## REAR PANEL DESCRIPTION

**INPUT POWER:** This tells you how much AC power (75 Watts) the amplifier can "draw" from the wall socket when the amplifier is at full power. The marking directly below tells you what the the wall socket Voltage and Frequency must be. Incorrect line voltage will damage your amplifier and VOID THE WARRANTY.

**LINE CORD:** The line cord should be connected to a suitable power source, with the correct voltage and frequency, as shown in the INPUT POWER at the amplifier rear. If you are not sure, check some other piece of equipment in your area. **DO NOT ALTER THE AC PLUG.**

## BXR 25 SPECIFICATIONS

PART NUMBER 022-4403

### POWER AMPLIFIER SECTION

Power output: 25 Watts  
Rated load impedance: 8 Ohms  
Distortion at rated power: 5%  
Power bandwidth: 20 Hz to 20kHz  
Input sensitivity: .90 VOLT R.M.S.  
Input impedance: >10k Ohms

### PREAMP SECTION

Input impedance: Input 1 > 220k Ohms  
Input 2 > 110k Ohms  
Sensitivity: Volume at maximum, all tone controls at "0" detent, power amp at 25 Watts, 8 Ohms  
Input 1 > 10mV  
Input 2 > 20mV

Equalization range: HIGH +/- 15 dB at 8kHz  
MID +/- 15 dB at 800 Hz  
LOW +/- 15 dB at 40 Hz

### PHYSICAL SPECIFICATIONS

Width: 14-3/4 inches (37.5 cm)  
Height: 18 inches (45.7 cm)  
Depth: 10 inches (25.4 cm)  
Weight: 32 lbs. (14.5 kg)  
Speaker: 1-10" Fender Special Design (P/N 038657)

Sound: *HUGE*

WARNING: NO USER SERVICEABLE PARTS INSIDE. REFER SERVICING TO QUALIFIED PERSONNEL ONLY.

## BXR 25 BLOCK DIAGRAM

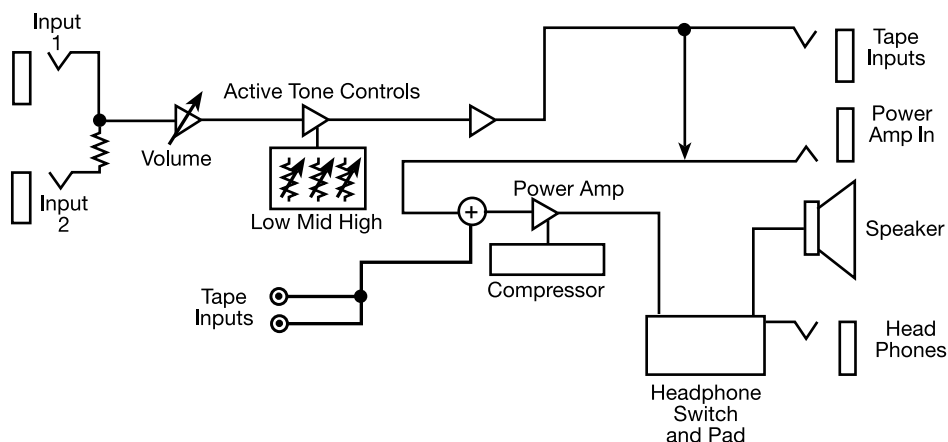

A PRODUCT OF:  
FENDER MUSICAL INSTRUMENTS CORP.,  
BREA, CA 92621