

Fender[®]

THE SOUND THAT CREATES LEGENDS

BASS
EXTENDED
RANGE **BXR**
Sixty

Owner's Manual

P/N 047538

BXR 60 Owner's Manual

Congratulations on your purchase of the Fender BXR 60 Bass amplifier. The Fender BXR 60 is the most recent effort in state-of-the-art bass amplifier technology, and is a member of the FENDER BXR series. The design of the BXR 60 was carried out with the aid of some of today's best bass players, and represents years of thought and consideration in determining features and specifications. The features included in the BXR 60 will provide a forum for almost every conceivable playing style, from "traditional" to "contemporary", and those yet to come.

The preamp section of the BXR 60 features two inputs of differing sensitivities, allowing for the use of a wide variety of input sources and levels. A MID NOTCH button is provided to enhance the mid frequency response. The 4-band EQ allows for up to 12 decibels of boost or cut in 4 bands between 80 Hz and 6KHz. The PREAMP OUT & POWER AMP IN jacks can be used as an effects loop or send and return points while slaving multiple amps together. A HEADPHONE jack automatically mutes the speaker while driving stereo headphones for private practice sessions. The quasi-balanced LINE OUT jack is used for "hum free" direct connection to recording and sound reinforcement equipment.

The rugged power amplifier is designed to give years of reliable service under all conditions. It is equipped with our exclusive DELTACOMP™ adaptive compressor system. With DELTACOMP™, it is practically impossible to clip (distort) the power amplifier. The apparent release time of the compressor is short, yet distortion at low frequencies is kept to a minimum.

The BXR 60's power amp drives a heavy duty twelve inch Fender Special Design loudspeaker.

The selection of a Fender amplifier will reward you with years of quality performance and a wide range of musical sounds. This manual is designed to familiarize you with the equipment and to acquaint you with its many features. Please read it carefully so you will benefit from all the features as soon as you start using the amplifier.

The built in quality of a Fender amplifier is the result of over four decades of dedication, and the combined skills of research and development by our engineers and musicians.

That is why we proudly say **FENDER, *The Sound That Creates Legends.***

WARNING: TO PREVENT FIRE OR SHOCK HAZARD, DO NOT EXPOSE THIS UNIT TO RAIN OR MOISTURE

BXR 60 Front Panel Functions

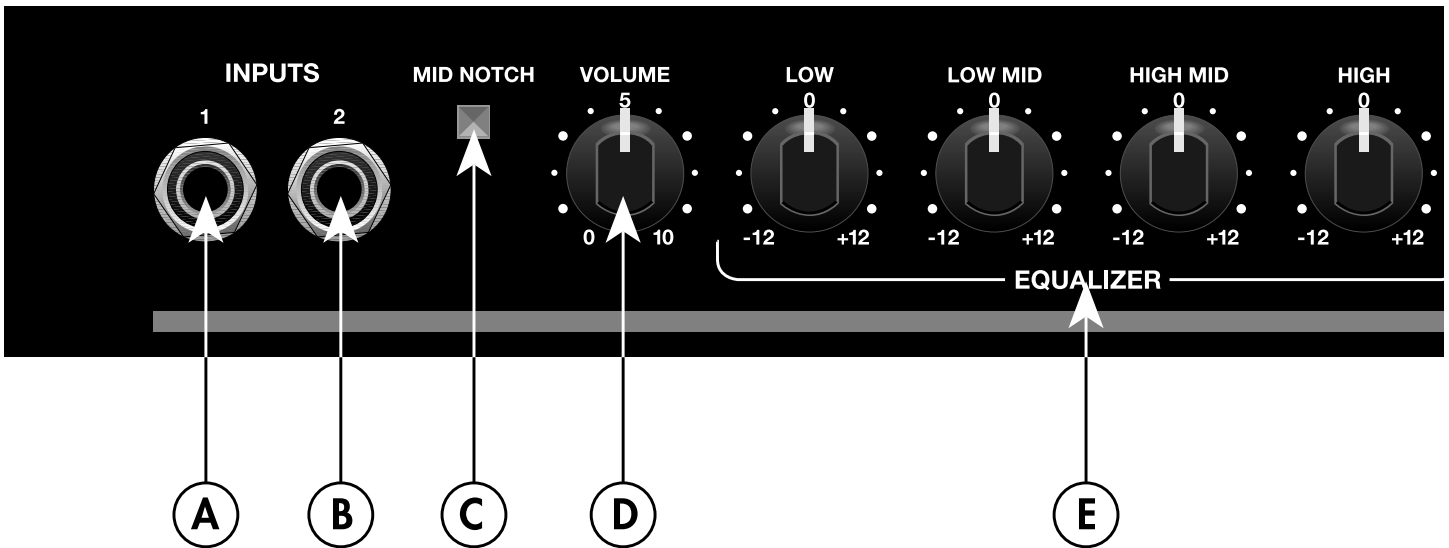

The front panel contains all items necessary for system operation and observation. Please read this section of the manual carefully to make sure you understand all the operational features for your new FENDER BXR 60 bass amplifier.

- A. INPUT 1** - A high impedance, high sensitivity plug-in connection for instruments. This input can handle as much as 2.5 volts R.M.S., and should be used with most instruments.
- B. INPUT 2** - Plug-in connection for instruments. This input is recommended for basses with active pickups, and can handle as much as 5 volts R.M.S..
- C. MID NOTCH switch** - removes midrange, making the amp sound "punchy". This switch is good for "thump and pluck" playing.
- D. VOLUME control** - adjusts the overall loudness of the amplifier.

- E. EQUALIZER** - allows adjustment of the tonal characteristics of the amplifier. Each control provides a 12 dB boost or cut to the low, low mid, high mid, and high frequency ranges.
- F. TAPE IN** - Plug-in connection for any line level (500mV) stereo or mono signal. This signal is mixed into the power amp along with the instrument signal from the preamp. It has fixed gain and is unaffected by any of the front panel controls; however the signal will be affected by any device inserted between the PREAMP OUT (item G) and the POWER AMP IN (item H). It is useful for patching in a CD or tape player, rhythm machine or other signal source to be used as an accompaniment for practice or performance. The output level control of the external signal source is used to control its own volume while the front panel VOLUME (item D) control is used for the instrument in order to obtain a balance.

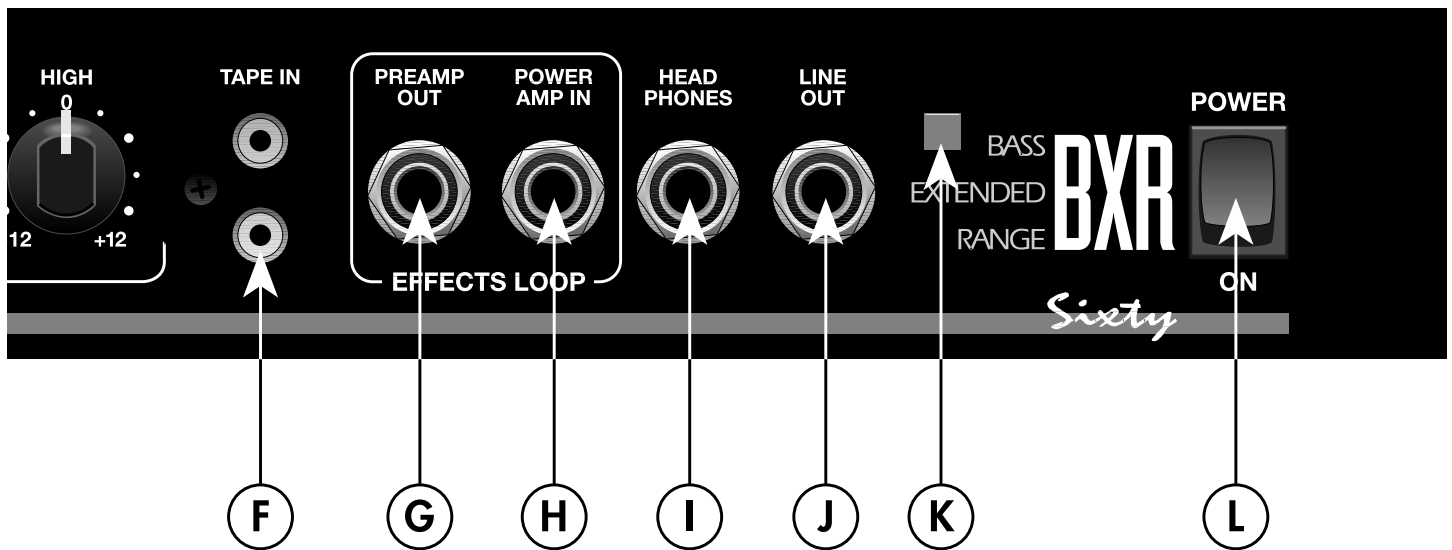

G. PREAMP OUT jack -This jack provides an unbalanced mono output signal from the preamp. This output can be used with the POWER AMP IN jack (item H) as a patch point for mono effects devices. It can also be used to provide a signal to a recording or sound reinforcement mixer. In addition, this output can be used to drive another BXR 60 used as a slave amp. This is done by connecting a standard guitar cord from the PREAMP OUT jack of the master amplifier to the POWER AMP IN jack (item H) of the slave.

H. POWER AMP IN jack - This unbalanced input goes directly into the power amp. It automatically disconnects the preamp when used. This jack is useful when using the effects loop feature, or when using the BXR 60 as a slave amp.

I. HEADPHONES output jack -This jack allows the use of stereo headphones for private listening. When this jack is used, the internal speaker is disconnected. **WARNING:**

BE CAREFUL WHEN USING HEADPHONES, AS EXCESSIVE VOLUME WILL RUIN YOUR HEARING!

J. LINE OUT jack - This quasi-balanced output is derived from the speaker, and is at line level, similar to that of the PREAMP OUT jack (item G). Since the LINE OUT jack is post-power amp, it provides a signal that is affected by the DELTACOMP™ adaptive compressor. The jack is wired TIP (+), RING (-), and SLEEVE ground. If the LINE OUT jack is used to connect to a balanced input, it will greatly reduce hum caused by a ground loop (a difference in ground potential) between the BXR 60 and another piece of equipment.

K. POWER INDICATOR - When this LED is illuminated, the BXR 60 is receiving power.

L. POWER SWITCH - turns the BXR 60 ON or OFF.

BXR 60 Rear Panel



NOTE: DO NOT BLOCK THE AIR FLOW TO THE REAR PANEL, FOR EXAMPLE, BY BACKING THE AMPLIFIER UP AGAINST A WALL. The rear panel is used to keep the output devices from getting too hot. Should the amplifier overheat, a thermal switch will shut the amplifier off until the output devices cool.

POWER CORD - This amplifier is equipped with a grounding type supply cord to reduce the possibility of shock hazard. Be sure to connect it to a grounded AC receptacle. The line cord should be connected to a suitable power source, in accordance with the voltage and frequency as shown by the power rating on the rear panel. **DO NOT ALTER THE THREE PRONG PLUG.**

COVERING CARE The exclusive vinyl covering your cabinet has been especially designed for years of lasting beauty. A very light, soapy solution on a sponge may be used to remove dirt and residue that may accumulate in the texture. Be careful not to let any liquid come in contact with the operating surfaces. **UNPLUG THE POWER CORD BEFORE CLEANING.**

Troubleshooters Checklist

If the amp is set up but does not function, check the following items:

- Is the amp power cord plugged into an electrical outlet?
 - Is there power at the outlet?
 - Are all the control knobs turned up?
 - Is the volume control on the instrument turned up?
 - Is the instrument properly plugged into the amplifier?
- (Eliminate any effect pedals and try another guitar cord.)

If, after checking all of the above, the system is still not performing correctly, consult your FENDER Service Dealer.

BXR 60 Specifications

Part Number:	120V Version:	22-4404
	230V Version:	22-4464
Type Specification:	PR 261	
Power Requirements:	100V Version:	100VAC, 50/60 Hz 180W
	120V Version:	120VAC, 60 Hz, 180W
	230V Version:	230VAC, 50 Hz, 180W
	240V Version:	240VAC, 50 Hz, 180W

POWER AMPLIFIER SECTION:

Power output:	60 watts R.M.S. @ 5% THD	
Rated load impedance:	8 Ohms	
Distortion:	Less than .1% @ 1 kHz, at onset of clipping, less than 1% @ 1 kHz, at maximum compression.	
Sensitivity:	0.95 volts R.M.S.	
Input impedance:	22k Ohms	
DELTA COMP™ range:	20 dB	

PREAMP SECTION:

Input impedance:	Input 1 -	Greater than 420k Ohms (typically greater than 1 megaohm in the passband)
	Input 2 -	136k Ohms
Sensitivity for 60 W: VOLUME at maximum, all tone controls at "0" detent, no enhancement activated.	Input 1 -	6 mV
	Input 2 -	12 mV
Equalizer:	+/- 12 dB at 80 Hz (low), 500 Hz (low mid), 2.5k Hz (high mid), and 6k Hz (high)	

PHYSICAL SPECIFICATIONS:

Height:	22-1/2 inches	(57.2 cm)
Width:	18 inches	(45.7 cm)
Depth:	12 inches	(30.5 cm)
Weight:	46 lbs.	(20.9 kg)
Speaker:	12" Fender Special Design (P/N 047539)	

**WARNING: NO USER SERVICEABLE PARTS INSIDE.
REFER SERVICING TO QUALIFIED PERSONNEL ONLY.**

BXR 60 Block Diagram

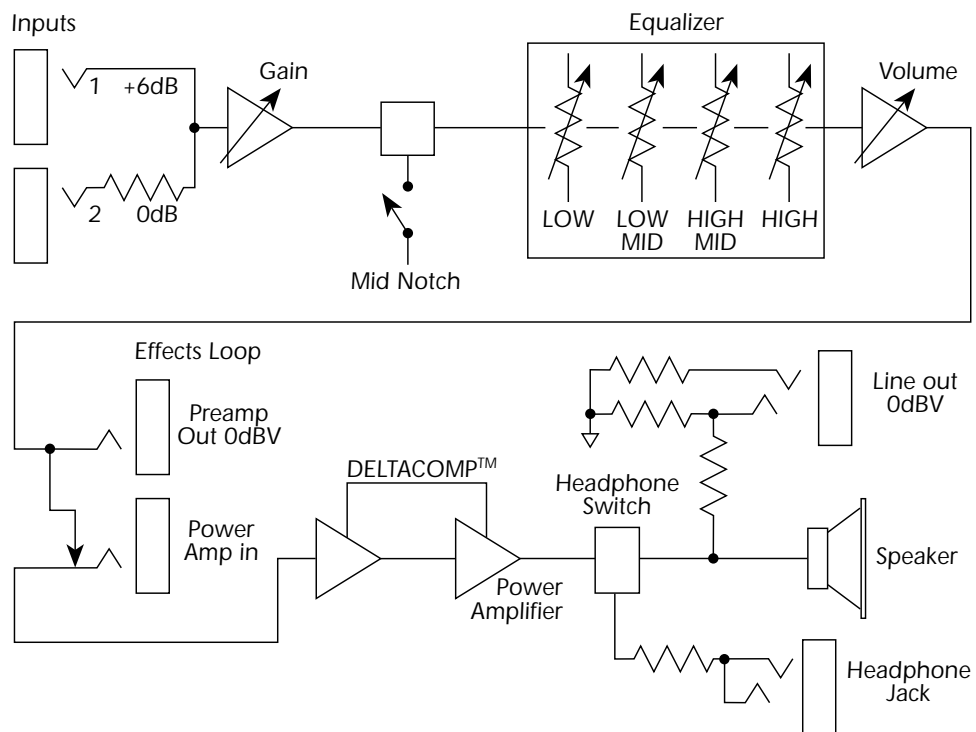

A PRODUCT OF:
FENDER MUSICAL INSTRUMENTS CORP.,
CORONA, CA 91720