



# 2026 CUSTOM GUITAR DESIGN GUIDE



LIMITED EDITION BOW TIE  
TELECASTER® CUSTOM RELIC®  
BLACK, GOLD HARDWARE  
9235700113



# FOREWORD

A Fender Custom Shop instrument is extraordinary. You know it when you play one—it's definitely more than the sum of its parts. It's filled with intangible, electrifying elements that add a new dimension to your playing experience. It's as if the instrument itself is imbued with history, alive with the spirit of the place where it was built and the devotion of those who crafted it.

The Custom Shop is home to Fender's most skilled and talented builders. It's a bustling, noisy and creatively volcanic place that re-earns its nickname—the Dream Factory—every day. Custom Shop builders are completely dedicated to their art—part craftsman, part artist, part music fan and, more often than not, part mad scientist. They're the best at what they do, and they pour all of their passion, hard-earned knowledge and skill into every instrument they build. It's no ordinary place and the creations that come from it are no ordinary instruments. Welcome to the Fender Custom Shop.

For players who wish to create a completely custom instrument—anything from a humbucking pickup-equipped banjo to a custom-engraved aluminum-bodied Strat®—we offer Masterbuilt, a singular experience working one-on-one with one of our Masterbuilders. Custom-Built is for those who prefer to start with one of our time-honored models and personalize the specifications to meet your specific needs. Use this guide to design your very own Masterbuilt or Custom-Built Fender guitar and make your dreams come true.

©2025 Fender Musical Instruments Corporation. FENDER®, STRATOCASTER®, STRAT®, TELECASTER®, TELE®, PRECISION BASS®, P BASS®, JAZZ BASS®, J BASS®, JAZZMASTER™, JAGUAR®, ESQUIRE®, NOCASTER®, RELIC®, CUNIFE® and the distinctive headstock designs commonly found on Fender guitars are registered trademarks of FMIC. All rights reserved.

All other trademarks are the property of their respective owners.

All Fender Custom Shop instruments are expertly crafted according to exact order specifications and arrive free of defects. Those instruments not abiding by this policy will be repaired, modified or replaced by us at no cost to you. Consult your local retailer, distributor or the Custom Care™ website ([customcare.fender.com](https://customcare.fender.com)) for details.

Fender Musical Instruments Corporation  
17600 North Perimeter Drive  
Scottsdale, AZ 85255-5440  
T: (480) 596-9690  
F: (480) 596-1384

[fendercustomshop.com](https://fendercustomshop.com)

All colors, features and specifications  
are subject to change without notice.

# CONTENTS

Ordering Yours.....	5
Masterbuilt.....	7
Masterbuilders.....	8
Custom-Built.....	13
Base Models.....	15
Stratocaster Models.....	16
Telecaster Models.....	18
Precision Bass Models.....	20
Jazz Bass Models.....	21
Offset Models.....	22
Aging Styles.....	23
Tonewood Options.....	28
Body Wood.....	28
Neck Wood.....	30
Color Options.....	31
Neck Shapes.....	35
Fret Wire.....	39
Pickup Option.....	41
Wiring Option.....	45
Hardware Options.....	52
Design Guide Order Form.....	58



# BUILD YOUR DREAM GUITAR

Every great instrument starts with an idea. The Fender Custom Shop turns your idea into a finely crafted reality.

## 01 SELECT A BUILD LEVEL

Masterbuilt or Custom-Built

## 02 SELECT A CUSTOM SHOP BASE MODEL

Choose from a wide range of guitars and basses

## 03 SELECT AN AGING PACKAGE

Choose your level of aging from NOS to Super Heavy Relic®

## 04 SELECT YOUR OPTIONS

Choose your custom options from our extensive menu of offerings

## 05 ADDITIONAL NOTES

Use the “additional notes” section if your desired options are not listed

## 06 SUBMIT YOUR ORDER

Take this completed design guide to a Custom Shop Showcase Dealer which you can find at [www.fendercustomshop.com/dealers/](http://www.fendercustomshop.com/dealers/)



01



## BUILD LEVEL: MASTERBUILT

In every art form there are those who have mastered their craft so thoroughly, through years of training and experience, their work routinely commands extra acclaim and admiration, not to mention outright awe. These astonishing artisans are the Masterbuilder of the Fender Custom Shop; a select group of the most talented builders recognized around the world for their matchless skill, limitless imagination and utter devotion to their art.

Crafting a guitar with a Custom Shop Masterbuilder is the ultimate artistic partnership—simply put, no idea is too crazy and no job too large or too small. They'll walk you through everything—body design, neck shape, tonewoods, pickups, hardware and more—to give you the look, feel and sound that you're searching for. From start to finish the Masterbuilder will personally ensure that each guitar is built with the highest possible quality and to your exact specifications. Additionally, it's about more than just specifications, it's about making the instrument of your dreams a concrete reality.

# MASTERBUILDERS

Imagine the greatest artists in history gathered under one roof: Michelangelo, DaVinci, Picasso and Dali working next to each other, sharing pigments, knowledge and expertise. The Fender Custom Shop is exactly that, the world's most esteemed luthiers gathered together to create peerless instruments that are astounding works of art—the Masterbuilders. They are known the world over for their skill and have built instruments for Jeff Beck, Ritchie Blackmore, Eric Clapton, Dick Dale, Mike Dirnt, Bob Dylan, Robben Ford, Buddy Guy, Merle Haggard, Reggie Hamilton, Mark Hoppus, John 5, Keith Richards, Sting and U2... just to name a few!

## DALE WILSON



*Dale Wilson*

Dale Wilson arrived at Fender in 2003, joined the Custom Shop in 2005 and became a Masterbuilder in 2011. Building guitars has been a driving passion for the California native since childhood. "Ever since I can remember, I've always loved guitars," he says. "I didn't dream of being a rock star; I dreamt of building the ultimate guitar. I was equally enthralled with the guitars just as much as I was with the players."

Woodworking runs in the Wilson family, and the requisite Custom Shop zeal for outstanding craftsmanship has long been part of Dale's DNA. He did repair work and mods in a small guitar shop

right out of high school in the late 1980s; subsequently, he moved on to stints at Dobro and Rickenbacker before arriving at Fender, where he worked on Guild, Gretsch and Benedetto guitars before beginning his apprenticeship with various Custom Shop Masterbuilders.

He enjoys calling upon his extensive and varied experience as a craftsman to create highly distinctive guitars such as the Resophonic Thinline Telecaster®. Wilson also built five beautiful custom guitars for the January 2011 NAMM Show while still an apprentice and was asked to sign the back of the headstocks, garnering him his Masterbuilder status.

## PAUL WALLER



*Paul Waller*

Paul Waller is a Southern California native with woodworking and luthiery in his blood. He built his first guitar at age 14 in his high school woodshop, joined a cabinet shop right out of high school and, after a stint at a small Southern California guitar maker, enrolled at the acclaimed Roberto-Venn School of Luthiery in Phoenix, from which he graduated in spring of 2000.

Waller joined Fender in 2003. He spent two years working closely with master archtop craftsman Bob Benedetto, and became steeped in the many facets of building techniques from all the Custom Shop's Masterbuilders. After an extensive

seven-year apprenticeship, Waller became a Masterbuilder in 2010.

His Fender Custom Shop work includes bass guitars for U2's Adam Clayton, a custom Thinline Telecaster for U2 vocalist Bono, Telecaster guitars for the Rolling Stones' Keith Richards and co-work on a Stratocaster for fellow Stones guitarist Ronnie Wood, Stratocaster guitars for Buddy Guy, the Nile Rodgers "Hitmaker" Stratocaster, a custom double-neck Jazzmaster for Queens of the Stone Age guitarist Troy Van Leeuwen, the George Harrison Tribute Rosewood Telecaster, and the George Harrison Rocky Stratocaster.

## JASON SMITH



A Custom Shop veteran and son of longtime Fender R&D legend Dan Smith, Jason Smith grew up on Fender—“It has always been in my family,” he says, “And I was always extremely interested in everything my father did.”

Born in Rochester, N.Y., and raised in California, Smith remembers meeting guitar greats from about age 5 on through his father’s work with Fender—Eric Clapton, Yngwie Malmsteen, Jeff Beck and Robben Ford, to name only a few. He went to his first big rock concert at age six—Rush—and remembers going backstage with his dad and meeting Geddy Lee after the show. Before he was even in his teens, Smith was

going to see Pink Floyd, ZZ Top and many other major artists. Rock music and Fender are part of Smith’s DNA. He joined the Fender Custom Shop in 1995 and in 2006 completed a five-year apprenticeship under acclaimed Senior Masterbuilder John English. Among many diverse projects with English, Smith worked on a pair of double-neck Stratocaster guitars for Stone Temple Pilots guitarist Dean DeLeo. He has since crafted fine instruments for players and acts including John 5, Michael Landau, Flea, Josh Klinghoffer, Steve Harris, Reggie Hamilton, Linkin Park, Kenny Wayne Shepherd, Neon Trees and many others.

## TODD KRAUSE



Todd Krause has built exquisitely crafted custom instruments for many of the world’s greatest artists, including Jeff Beck, Eric Clapton, Bob Dylan, David Gilmour, Robbie Robertson, Kenny Wayne Shepherd, Robin Trower, Roger Waters and many others.

His guitar-building apprenticeship began in early 1981 at Jackson/Charvel guitars. Krause arrived at Fender in 1991 and steadily rose through several roles,

including one-off instrument builder, R&D model maker and woodworking machinist. He became a Custom Shop Masterbuilder in 1997 and has created countless distinctive instruments, all of which embody his personal design philosophy: “Form and function are the biggest part of it,” he says. “It’s about the way an instrument sounds and feels. It has to look cool, and it has to compel you to play.”

## YURIY SHISHKOV



From handcrafting many of his own woodworking tools to showcasing his world-class luthier skills and custom inlay work, Yuriy Shishkov is truly one of the last of the renaissance guitar builders. It was in the small confines of a root cellar in his hometown of Gomel in the former Soviet Union that Shishkov got his start building guitars for friends and colleagues.

When he arrived in the United States in 1990, Shishkov settled in the Chicago area

and collaborated with a range of top artists, including late shredder Dimebag Darrell, Jimmy Page and Robert Plant, Nuno Bettencourt and Paul Stanley of Kiss. Shishkov joined the Fender Custom Shop’s Masterbuilder team in 2000, and continues to craft truly magnificent instruments featuring exquisite detail and inlay work as the Fender Custom Shop’s Principal Masterbuilder.

## GREG FESSLER

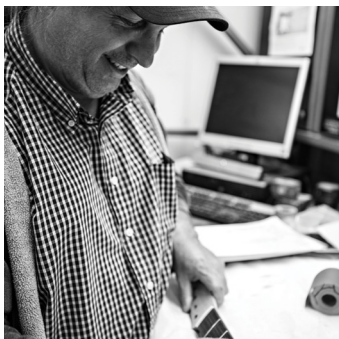

Greg Fessler came to the Fender Custom Shop in 1990, working his way up through the ranks as an apprentice. He assisted with the Robben Ford signature line of guitars, eventually becoming the sole builder of those instruments and, later, Ford's personal builder. Fessler has built one-off Stratocaster and Telecaster models for a host of players, including Joe Bonamassa, Jeff Healey, Hank Marvin, John Mayer, Rhonda Smith, Neil Schon and Pete Wentz, to name a few.

Fessler's remarkable abilities as a Masterbuilder have earned him accolades from many Fender artists and from discerning customers worldwide. His meticulous attention to detail is exemplified in every instrument he creates, each of which is a perfect example of the intense commitment it takes to earn the title of Masterbuilder.

## DENNIS GALUSZKA



Like Fender itself, Dennis Galuszka is a Southern California native. Combining his dual passions for music and woodworking, he began building high-end acoustic guitars during his 13 years as a cabinetmaker. As a working drummer, it was a 1999 audition with one of the Fender Masterbuilders that led to a job interview and a new kind of steady gig—as an apprentice at the Fender Custom Shop.

After only eight months there, Galuszka was promoted to Masterbuilder. He has

since built finely crafted instruments for influential players including Paul McCartney, Andy Summers, Johnny Marr, Patrick Stump, Mike Dirnt, Sting and many others. He has lent his expertise to a number of truly distinctive instruments, including double-neck guitars and unusual takes on classic Fender designs along with several artist models. "It's all about the feel and sound of an instrument," Galuszka says. "Those things are number one with me, above everything else."

## KYLE MCMILLIN



Kyle McMillin brings 15 years of musical instrument experience to the Fender Custom Shop. McMillin recently finished a five-year apprenticeship under Principal Masterbuilder Yuriy Shishkov—working on nearly 1,000 guitars while learning from the esteemed builder. As a newly-minted Masterbuilder, McMillin is now part of a team of the finest guitar builders—the Fender Custom Shop.

## AUSTIN MACNUTT



Canadian born in a family of performing musicians, some of Austin's earliest memories contain acoustic and electric guitars, including his father's 1963 Custom Color Black Fender Jaguar with matching headstock that is still in the family. Following in his parents' footsteps, he took up guitar playing at the age of 10 and soon found himself tinkering on it to improve playability and tone. Throughout his teens, Austin developed his building and repair skills and became the local go-to repair tech for many of the bands passing through.

After graduating high school in Saskatoon, Austin saved up and enrolled himself at the Guitar Craft Academy in Hollywood to further his skills and passion

for guitar building. Recognizing his talents, immediately after completing the course the school offered him a position as one of their teachers. During these five years of teaching guitar building, he met Ron Thorn during an inlay seminar, and shortly after was offered a position at Thorn Guitars. For 11 years Austin crafted boutique electric guitars under the Thorn brand. From raw lumber selection, millwork, CNC operation, fretwork and final assembly, Austin did it all and once again is working shoulder to shoulder with his old friend, crafting Fender's finest.

When Austin is not building guitars, he enjoys spending his time with his girlfriend, playing music and going camping whenever and wherever he can.

## ANDY HICKS



Andy Hicks grew up in a household filled with music lovers. He received his first guitar on his 11th birthday—a gorgeous 3-Tone Burst Fender Stratocaster. Andy spent his teenage years playing along with his favorite Nirvana, Black Sabbath and Metallica records. He played in local rock bands and by his early 20s he became increasingly interested in experimenting with guitars by modifying pickups and wiring.

In 2009, Andy decided to take this passion for guitar building seriously by enrolling in the Guitar Craft Academy in Hollywood, a six-month program focused on electric guitars. Within a week of graduating, he started working at Fender in the Jackson Custom Shop, dressing frets. From 2013 to 2018, he worked as an assistant to Gretsch Custom Shop Senior Masterbuilder, Steve Stern. Andy worked with various artists during this period and is very proud of his involvement with the Malcolm Young "Salute" Jet. In 2018, Andy seized the opportunity to become the lead builder and production manager for a high-end boutique guitar company and was subsequently recruited by James Tyler to

oversee production for his shop in the San Fernando Valley.

On his return to Fender, Hicks said, "coming back to Fender, becoming part of the most prestigious custom shop in the industry, and being around so many talented builders is incredibly exciting and humbling. It also feels like I have returned home."

When it comes to guitars, Andy incorporates his two passions: playing and building guitars. He firmly believes that these two passions are deeply connected, uniting Andy's core approach to creating guitars. "I love interacting with guitarists," Hicks says. "Bridging the gap between builder and player, listening to their desires and implementing them into my builds is incredibly rewarding. Nothing could be better."

When not building guitars, Andy plays in an epic doom metal band, Stygian Crown, enjoys playing Dungeons and Dragons and goes on incredible Disneyland trips with his wife and three boys.

## DAVID BROWN



David Brown's music adventure began in the late '70s while he was in middle school. By the time he was in high school, he was playing in bands and working at a local store in Anaheim where he learned guitar repair and construction. By the mid '80s, he was working for Yamaha Music Corp. in Buena Park as a guitar technician. In 2000, David got the opportunity to work at Fender and thus began his career with the company. By 2006, he received a degree in marketing from California State University at Fullerton and was now working in the Fender Custom Shop building new models as well as making instruments for various artists.

"I hope to bring a perspective that takes into account all of my previous experiences in guitar building and construction," he says. "I hope to create these instruments that are the industry standard when it comes to accuracy and feel for the musician. Becoming a Masterbuilder for the Fender Custom Shop means that you've arrived. There is no higher pinnacle than this."

In 2009, David and Fender parted ways only for him to return two years later to manage the new Fender Visitor Center which was located next to the Corona manufacturing facility. While in this position, David was the first point of contact with the company's customer base as they toured the factory and participated in building their own custom-made instruments. In 2016, the FVC closed and David departed from Fender once more. By 2017, he was managing the new G&L Custom Shop in Fullerton, California where he was the principal builder until 2020. David returned to school to pursue a teaching credential in math, but the opportunity to work once again in the Fender Custom Shop altered his course.

Apart from electric guitars being his passion, David enjoys designing and building tube amplifiers and playing original music with his classic rock band. He and his wife enjoy traveling abroad as well as rescuing and fostering dogs and cats. He also enjoys black and white landscape photography.

12

## LEVI PERRY



Levi Perry started at Fender's U.S. production final assembly department in 2012, fresh out of high school in Riverside, California, where he was born and raised. He moved to the Custom Shop three years later in 2015, as a Relic artisan and tune tester and soon moved to service repair. After another three years he was promoted to Masterbuilder Apprentice in 2018.

While an apprentice Perry served as a "floater," which meant that he worked with and learned from each Masterbuilder individually. He worked on many prestigious builds during this period, including the Game of Thrones series,

the Limited Edition Phil Lynott Precision Bass, the Limited Edition George Harrison Rocky Strat, the Limited Edition El Mocambo Heavy Relic Stratocaster and Telecaster models, and many other collections and artist instruments.

"For me, what's important is to always be learning and growing, and to remain a student of the craft," Perry says. "Fender has such a deep and rich history to glean from, and when you allow that history to teach and guide you while continuing to be creative and push the boundaries, you'll be amazed at what you can create."



01



## BUILD LEVEL: CUSTOM-BUILT

Your dreams are what make the Fender Custom Shop the reality that it is today. From its inception in 1987, the Custom Shop has grown from two builders to today's more than 50 artisans—a veteran band of builders, each a specialist dedicated to their own area of expertise—working together to build your ideal Fender to your exact specifications. From neck shaping and fretwork to finishing and aging—every step of creation—each Custom Shop craftsman brings years of hard-earned skill and dedication to bear on your Custom-Built guitar with one goal in mind: to create an instrument and playing experience that can only come from the Fender Custom Shop.

A Fender Custom-Built guitar lets you define your ideal instrument. Begin with one of our base models and choose from our vast selection of options to customize it as little or as much as you want to meet your personal needs, aesthetic taste and playing style.

Whatever shape your dream may be, our luthiers stand ready to craft an instrument that will unlock your utmost creativity and self-expression. Their passion is bringing your dreams to reality, to create the ultimate instrument—one personally customized exclusively for you.



02



## SELECT A BASE MODEL

Each base model includes specifications listed as period accurate but can be customized based on the player's playing style and taste.

# STRATOCASTER® BASE MODELS

## 1955 STRATOCASTER

SHOWN IN 2-COLOR SUNBURST



**BODY WOOD** ASH  
**BODY FINISH** NITROCELLULOSE LACQUER  
**NECK WOOD** MAPLE  
**NECK SHAPE** '55 "U"  
**FINGERBOARD** 1-PIECE MAPLE  
**RADIUS** 7.25"  
**FRET SIZE** VINTAGE  
**FACE DOTS** BLACK MICARTA - WIDE SPACING  
**NUT** MICARTA  
**TUNERS** FENDER GOTOH VINTAGE  
**HARDWARE** NICKEL / CHROME  
**BRIDGE** VINTAGE SYNCHRONIZED TREMOLO  
**PICKGUARD** 1-PLY WHITE  
**WIRING** VINTAGE STRAT W/ 5-WAY SWITCH  
**PICKUPS** FCS 1950S STRAT

## 1956 STRATOCASTER

SHOWN IN WHITE BLONDE



**BODY WOOD** ALDER  
**BODY FINISH** NITROCELLULOSE LACQUER  
**NECK WOOD** MAPLE  
**NECK SHAPE** 10/56 "V"  
**FINGERBOARD** 1-PIECE MAPLE  
**RADIUS** 7.25"  
**FRET SIZE** VINTAGE  
**FACE DOTS** BLACK MICARTA - WIDE SPACING  
**NUT** MICARTA  
**TUNERS** FENDER GOTOH VINTAGE  
**HARDWARE** NICKEL / CHROME  
**BRIDGE** VINTAGE SYNCHRONIZED TREMOLO  
**PICKGUARD** 1-PLY WHITE  
**WIRING** VINTAGE STRAT W/ 5-WAY SWITCH  
**PICKUPS** FCS 1950S STRAT

## 1960 STRATOCASTER

SHOWN IN DAKOTA RED

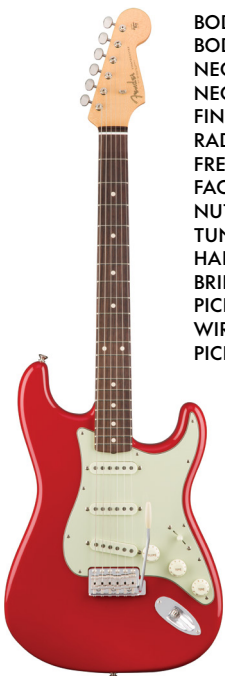

**BODY WOOD** ALDER  
**BODY FINISH** NITROCELLULOSE LACQUER  
**NECK WOOD** MAPLE  
**NECK SHAPE** '60S OVAL "C"  
**FINGERBOARD** SLAB ROSEWOOD  
**RADIUS** 7.25"  
**FRET SIZE** VINTAGE  
**FACE DOTS** WHITE MICARTA  
**NUT** MICARTA  
**TUNERS** FENDER GOTOH VINTAGE  
**HARDWARE** NICKEL / CHROME  
**BRIDGE** VINTAGE SYNCHRONIZED TREMOLO  
**PICKGUARD** 3-PLY WHITE  
**WIRING** VINTAGE STRAT W/ 5-WAY SWITCH  
**PICKUPS** FCS 1960S STRAT

## 1963 STRATOCASTER

SHOWN IN 3-COLOR SUNBURST



**BODY WOOD** ALDER  
**BODY FINISH** NITROCELLULOSE LACQUER  
**NECK WOOD** MAPLE  
**NECK SHAPE** 60S OVAL "C"  
**FINGERBOARD** ROUND-LAM ROSEWOOD  
**RADIUS** 7.25"  
**FRET SIZE** VINTAGE  
**FACE DOTS** WHITE MICARTA  
**NUT** MICARTA  
**TUNERS** FENDER GOTOH VINTAGE  
**HARDWARE** NICKEL / CHROME  
**BRIDGE** VINTAGE SYNCHRONIZED TREMOLO  
**PICKGUARD** 3-PLY WHITE  
**WIRING** VINTAGE STRAT W/ 5-WAY SWITCH  
**PICKUPS** FCS 1960S STRAT

## 1965 STRATOCASTER

SHOWN IN AZTEC GOLD



**BODY WOOD** ALDER  
**BODY FINISH** NITROCELLULOSE LACQUER  
**NECK WOOD** MAPLE  
**NECK SHAPE** '65 "C"  
**FINGERBOARD** ROUND-LAM ROSEWOOD  
**RADIUS** 7.25"  
**FRET SIZE** VINTAGE  
**FACE DOTS** PEARL - NARROW SPACING  
**NUT** MICARTA  
**TUNERS** FENDER GOTOH VINTAGE  
**HARDWARE** NICKEL / CHROME  
**BRIDGE** VINTAGE SYNCHRONIZED TREMOLO  
**PICKGUARD** 3-PLY WHITE  
**WIRING** VINTAGE STRAT W/ 5-WAY SWITCH  
**PICKUPS** FCS 1965 STRAT

## 1966 STRATOCASTER

SHOWN IN LAKE PLACID BLUE



**BODY WOOD** ALDER  
**BODY FINISH** NITROCELLULOSE LACQUER  
**NECK WOOD** MAPLE  
**NECK SHAPE** '66 OVAL "C"  
**FINGERBOARD** ROUND-LAM ROSEWOOD  
**RADIUS** 7.25"  
**FRET SIZE** VINTAGE  
**FACE DOTS** PEARL WHITE  
**NUT** MICARTA  
**TUNERS** FENDER GOTOH VINTAGE  
**HARDWARE** NICKEL / CHROME  
**BRIDGE** VINTAGE SYNCHRONIZED TREMOLO  
**PICKGUARD** 3-PLY WHITE  
**WIRING** VINTAGE STRAT W/ 5-WAY SWITCH  
**PICKUPS** FCS 1966 STRAT

## 1969 STRATOCASTER

SHOWN IN SONIC BLUE



**BODY WOOD** ALDER  
**BODY FINISH** NITROCELLULOSE LACQUER  
**NECK WOOD** MAPLE - URETHANE FINISH  
**NECK SHAPE** '69 "C"  
**FINGERBOARD** ROUND-LAM ROSEWOOD OR MAPLE  
**RADIUS** 7.25"  
**FRET SIZE** VINTAGE  
**FACE DOTS** PEARL WHITE OR BLACK MICARTA  
**NUT** MICARTA  
**TUNERS** SCHALLER "F"  
**HARDWARE** NICKEL / CHROME  
**BRIDGE** VINTAGE SYNCHRONIZED TREMOLO  
**PICKGUARD** 3-PLY WHITE  
**WIRING** VINTAGE STRAT W/ 5-WAY SWITCH  
**PICKUPS** FCS 1969 STRAT

# TELECASTER® BASE MODELS

## 1951 NOCASTER®

SHOWN IN HONEY BLONDE



**BODY WOOD** ASH  
**BODY FINISH** NITROCELLULOSE LACQUER  
**NECK WOOD** MAPLE  
**NECK SHAPE** NOCASTER "U"  
**FINGERBOARD** 1-PIECE MAPLE  
**RADIUS** 7.25"  
**FRET SIZE** F VINTAGE  
**FACE DOTS** BLACK MICARTA - NARROW SPACING  
**NUT** MICARTA  
**TUNERS** FENDER GOTOH VINTAGE  
**HARDWARE** NICKEL / CHROME  
**BRIDGE** VINTAGE WITH BRASS SADDLES  
**PICKGUARD** 1-PLY BLACK  
**WIRING** VINTAGE TELE W/ 3-WAY SWITCH  
**PICKUPS** FCS 1951 NOCASTER

## 1952 TELECASTER

SHOWN IN 2-COLOR SUNBURST



**BODY WOOD** ASH  
**BODY FINISH** NITROCELLULOSE LACQUER  
**NECK WOOD** MAPLE  
**NECK SHAPE** '52 "U"  
**FINGERBOARD** 1-PIECE MAPLE  
**RADIUS** 7.25"  
**FRET SIZE** VINTAGE  
**FACE DOTS** BLACK MICARTA - WIDE SPACING  
**NUT** MICARTA  
**TUNERS** FENDER GOTOH VINTAGE  
**HARDWARE** NICKEL / CHROME  
**BRIDGE** VINTAGE WITH BRASS SADDLES  
**PICKGUARD** 1-PLY BLACK  
**WIRING** VINTAGE TELE W/ 3-WAY SWITCH  
**PICKUPS** FCS 1951 NOCASTER

## 1960 TELECASTER

SHOWN IN WHITE BLONDE



**BODY WOOD** ALDER  
**BODY FINISH** NITROCELLULOSE LACQUER  
**NECK WOOD** MAPLE  
**NECK SHAPE** '60S OVAL "C"  
**FINGERBOARD** SLAB ROSEWOOD  
**RADIUS** 7.25"  
**FRET SIZE** VINTAGE  
**FACE DOTS** CLAY - NARROW SPACING  
**NUT** MICARTA  
**TUNERS** FENDER GOTOH VINTAGE  
**HARDWARE** NICKEL / CHROME  
**BRIDGE** VINTAGE WITH THREADED SADDLES  
**PICKGUARD** 3-PLY WHITE  
**WIRING** VINTAGE TELE W/ 3-WAY SWITCH  
**PICKUPS** FCS '60 - '63 TELECASTER

## 1960 TELECASTER CUSTOM

SHOWN IN BLACK



**BODY WOOD** DOUBLE-BOUND ALDER  
**BODY FINISH** NITROCELLULOSE LACQUER  
**NECK WOOD** MAPLE  
**NECK SHAPE** '60S OVAL "C"  
**FINGERBOARD** SLAB ROSEWOOD  
**RADIUS** 7.25"  
**FRET SIZE** VINTAGE  
**FACE DOTS** CLAY  
**NUT** MICARTA  
**TUNERS** FENDER GOTOH VINTAGE  
**HARDWARE** NICKEL / CHROME  
**BRIDGE** VINTAGE WITH THREADED SADDLES  
**PICKGUARD** 3-PLY WHITE  
**WIRING** VINTAGE TELE W/ 3-WAY SWITCH  
**PICKUPS** FCS '60 - '63 TELECASTER

## 1963 TELECASTER

SHOWN IN LAKE PLACID BLUE



**BODY WOOD** ALDER  
**BODY FINISH** NITROCELLULOSE LACQUER  
**NECK WOOD** MAPLE  
**NECK SHAPE** '60S OVAL "C"  
**FINGERBOARD** ROUND-LAM ROSEWOOD  
**RADIUS** 7.25"  
**FRET SIZE** VINTAGE  
**FACE DOTS** MICARTA WHITE  
**NUT** MICARTA  
**TUNERS** FENDER GOTOH VINTAGE  
**HARDWARE** NICKEL / CHROME  
**BRIDGE** VINTAGE WITH THREADED SADDLES  
**PICKGUARD** 3-PLY WHITE  
**WIRING** VINTAGE TELE W/ 3-WAY SWITCH  
**PICKUPS** FCS '60 - '63 TELECASTER

## 1967 TELECASTER

SHOWN IN CANDY APPLE RED



**BODY WOOD** ALDER  
**BODY FINISH** NITROCELLULOSE LACQUER  
**NECK WOOD** MAPLE  
**NECK SHAPE** '60S OVAL "C"  
**FINGERBOARD** ROSEWOOD OR MAPLE  
**RADIUS** 7.25"  
**FRET SIZE** VINTAGE  
**FACE DOTS** PEARL WHITE OR BLACK MICARTA  
**NUT** MICARTA  
**TUNERS** SCHALLER "F"  
**HARDWARE** NICKEL / CHROME  
**BRIDGE** VINTAGE WITH THREADED SADDLES  
**PICKGUARD** 3-PLY WHITE  
**WIRING** VINTAGE TELE W/ 3-WAY SWITCH  
**PICKUPS** FCS 1967 TELECASTER

## 1959 ESQUIRE®

SHOWN IN 3-COLOR SUNBURST



**BODY WOOD** ASH  
**BODY FINISH** NITROCELLULOSE LACQUER  
**NECK WOOD** MAPLE  
**NECK SHAPE** '59 "C"  
**FINGERBOARD** SLAB ROSEWOOD OR MAPLE  
**RADIUS** 7.25"  
**FRET SIZE** VINTAGE  
**FACE DOTS** MICARTA WHITE OR BLACK  
**NUT** MICARTA  
**TUNERS** FENDER GOTOH VINTAGE  
**HARDWARE** NICKEL / CHROME  
**BRIDGE** VINTAGE '59 W/ THREADED  
**PICKGUARD** 1-PLY PARCHMENT  
**WIRING** VINTAGE ESQUIRE 3-WAY SWITCH  
**PICKUPS** FCS VINTAGE TELECASTER

## 1960s THINLINE TELECASTER

SHOWN IN AGED NATURAL



**BODY WOOD** MAHOGANY  
**BODY FINISH** NITROCELLULOSE LACQUER  
**NECK WOOD** MAPLE  
**NECK SHAPE** '60S OVAL "C"  
**FINGERBOARD** ROUND-LAM MAPLE  
**RADIUS** 7.25"  
**FRET SIZE** VINTAGE  
**FACE DOTS** BLACK MICARTA  
**NUT** MICARTA  
**TUNERS** SCHALLER "F"  
**HARDWARE** NICKEL / CHROME  
**BRIDGE** VINTAGE WITH SLOTTED SADDLES  
**PICKGUARD** 4-PLY WHITE PEARLOID  
**WIRING** VINTAGE TELE W/ 3-WAY SWITCH  
**PICKUPS** FCS 1967 TELECASTER

# PRECISION BASS® BASE MODELS

## 1955 PRECISION BASS

SHOWN IN VINTAGE BLONDE



BODY WOOD	ASH
BODY FINISH	NITROCELLULOSE LACQUER
NECK WOOD	QUARTERSAWN MAPLE
NECK SHAPE	'55 PBASS SOFT "V"
FINGERBOARD	1-PIECE MAPLE
RADIUS	7.25"
FRET SIZE	VINTAGE
FACE DOTS	BLACK MICARTA
NUT	MICARTA
TUNERS	FENDER GOTOH REVERSE
HARDWARE	NICKEL / CHROME
BRIDGE	VINTAGE
PICKGUARD	1-PLY WHITE
WIRING	VINTAGE PRECISION BASS
PICKUPS	FCS 1950S PRECISION BASS

## 1959 PRECISION BASS

SHOWN IN BLACK



BODY WOOD	ALDER
BODY FINISH	NITROCELLULOSE LACQUER
NECK WOOD	QUARTERSAWN MAPLE
NECK SHAPE	'60S PBASS OVAL "C"
FINGERBOARD	SLAB ROSEWOOD
RADIUS	7.25"
FRET SIZE	VINTAGE
FACE DOTS	WHITE MICARTA
NUT	MICARTA
TUNERS	FENDER GOTOH REVERSE
HARDWARE	NICKEL / CHROME
BRIDGE	VINTAGE
PICKGUARD	GOLD ANODIZED
WIRING	VINTAGE PRECISION BASS
PICKUPS	FCS '59 - '62 BASS

## 1960 PRECISION BASS

SHOWN IN 3-COLOR SUNBURST



BODY WOOD	ASH
BODY FINISH	NITROCELLULOSE LACQUER
NECK WOOD	MAPLE
NECK SHAPE	'60S PBASS OVAL "C"
FINGERBOARD	SLAB ROSEWOOD
RADIUS	7.25"
FRET SIZE	VINTAGE
FACE DOTS	WHITE MICARTA
NUT	MICARTA
TUNERS	FENDER GOTOH REVERSE
HARDWARE	NICKEL / CHROME
BRIDGE	VINTAGE
PICKGUARD	4-PLY TORTOISE SHELL
WIRING	VINTAGE PRECISION BASS
PICKUPS	FCS '59 - '62 BASS

# JAZZ BASS® BASE MODELS

## 1964 JAZZ BASS

SHOWN IN SONIC BLUE



BODY WOOD	ALDER
BODY FINISH	NITROCELLULOSE LACQUER
NECK WOOD	MAPLE
NECK SHAPE	'60 "U"
FINGERBOARD	ROUND-LAM ROSEWOOD
RADIUS	7.25"
FRET SIZE	VINTAGE
FACE DOTS	WHITE MICARTA
NUT	MICARTA
TUNERS	FENDER GOTOH REVERSE
HARDWARE	NICKEL / CHROME
BRIDGE	VINTAGE
PICKGUARD	4-PLY TORTOISE SHELL
WIRING	VINTAGE JAZZ BASS
PICKUPS	FCS VINTAGE JAZZ BASS

## 1975 JAZZ BASS

SHOWN IN NATURAL



BODY WOOD	ASH
BODY FINISH	NITROCELLULOSE LACQUER
NECK WOOD	MAPLE
NECK SHAPE	'75 JAZZ BASS "C"
FINGERBOARD	ROUND-LAM ROSEWOOD OR MAPLE
RADIUS	7.25"
FRET SIZE	MEDIUM JUMBO
FACE DOTS	PEARL WHITE OR BLACK BLOCKS
NUT	MICARTA
TUNERS	FENDER GOTOH
HARDWARE	NICKEL / CHROME
BRIDGE	VINTAGE
PICKGUARD	3-PLY BLACK
WIRING	VINTAGE JAZZ BASS
PICKUPS	FCS VINTAGE JAZZ BASS

# OFFSET BASE MODELS

## 1962 JAZZMASTER®

SHOWN IN SURF GREEN



BODY WOOD	ALDER
BODY FINISH	NITROCELLULOSE LACQUER
NECK WOOD	MAPLE
NECK SHAPE	JAZZMASTER "C"
FINGERBOARD	SLAB ROSEWOOD
RADIUS	7.25"
FRET SIZE	VINTAGE
FACE DOTS	WHITE MICARTA
NUT	MICARTA
TUNERS	FENDER GOTOH VINTAGE
HARDWARE	NICKEL / CHROME
BRIDGE	VINTAGE JAGUAR / JAZZMASTER
PICKGUARD	3-PLY WHITE
WIRING	VINTAGE JAZZMASTER
PICKUPS	FCS JAZZMASTER

## 1962 JAGUAR®

SHOWN IN FIESTA RED



BODY WOOD	ALDER
BODY FINISH	NITROCELLULOSE LACQUER
NECK WOOD	MAPLE
NECK SHAPE	JAGUAR "C"
FINGERBOARD	SLAB ROSEWOOD
RADIUS	7.25"
FRET SIZE	VINTAGE
FACE DOTS	WHITE MICARTA
NUT	MICARTA
TUNERS	FENDER GOTOH VINTAGE
HARDWARE	NICKEL / CHROME
BRIDGE	VINTAGE JAGUAR / JAZZMASTER
PICKGUARD	3-PLY WHITE
WIRING	VINTAGE JAGUAR
PICKUPS	FCS JAGUAR

## BASS VI

SHOWN IN 3-COLOR SUNBURST



BODY WOOD	ALDER
BODY FINISH	NITROCELLULOSE LACQUER
NECK WOOD	QUARTERSAWN MAPLE
NECK SHAPE	"C"
FINGERBOARD	SLAB ROSEWOOD
RADIUS	7.25"
FRET SIZE	VINTAGE
FACE DOTS	WHITE MICARTA
NUT	MICARTA
TUNERS	FENDER GOTOH VINTAGE
HARDWARE	NICKEL / CHROME
BRIDGE	VINTAGE JAGUAR
PICKGUARD	4-PLY TORTOISE SHELL
WIRING	VINTAGE BASS VI
PICKUPS	FCS JAGUAR

03



SELECT AN  
**AGING STYLE**



# TIME CAPSULE

SHOW IN '52 TELECASTER®  
IN FADED NOCASTER® BLONDE

Combining our original "No Buff" NOS Flash Coat Lacquer finish with Closet Classic hardware, the Time Capsule package grants these instruments the charming appearance, authentic sound and genuine mojo of an extremely lucky vintage find.



# NEW OLD STOCK (NOS)

SHOWN IN VINTAGE CUSTOM '55 HARDTAIL STRAT  
IN AGED WHITE BLONDE

Models from the past that have survived to the present day looking brand new. An all-lacquer finish that looks as if it hasn't aged at all—as if you went back in time and bought it.



# DLX CLOSET CLASSIC™

SHOWN IN 1967 JAZZMASTER  
IN AGED LAKE PLACID BLUE

Well taken care of and religiously polished throughout the years. The owner of this guitar took pride in keeping it clean and shiny. Over time, the finish started showing age and like a fine wine it evolved into something complex and refined. Moderate finish checking, oxidation of hardware and mild discoloration of parts give this finish its distinct look and feel.

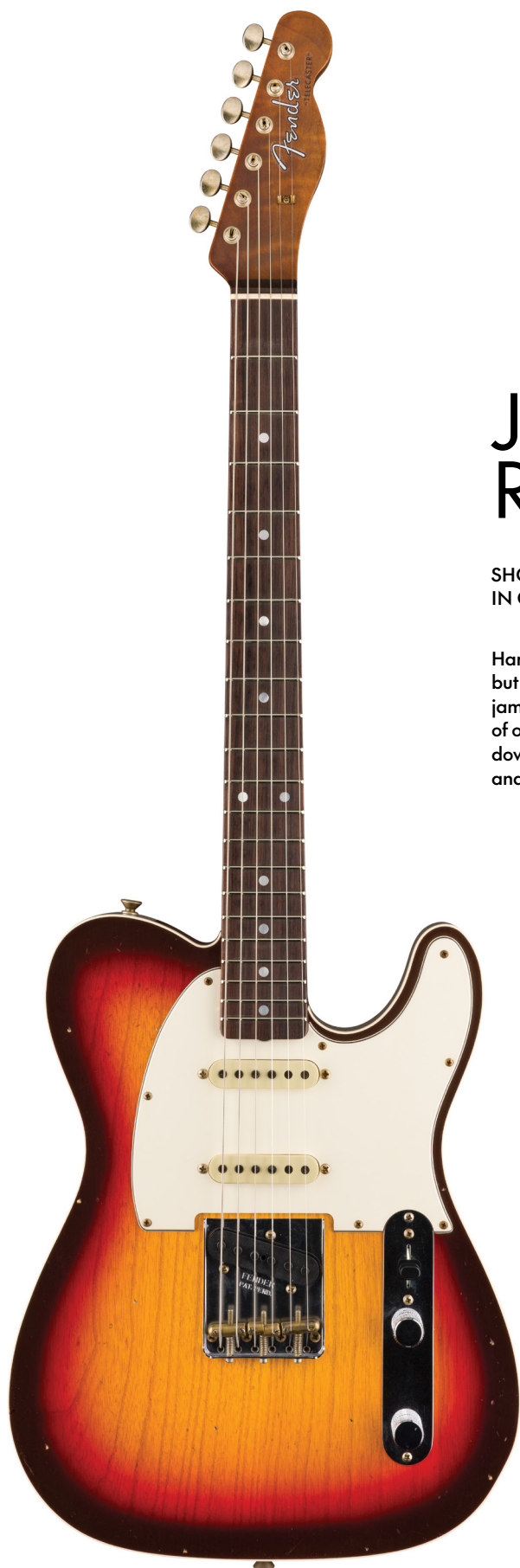

# JOURNEYMAN RELIC®

SHOWN IN LIMITED EDITION HOTSHOT TELE  
IN CHOCOLATE 3-COLOR SUNBURST

Handed down or changed hands through the years, but mostly played around the house, with the occasional jam session or weekend gig. Has been well taken care of over the years but has finish checking, some friendly down-to-the-wood nicks and dings, dullish hardware, and moderate playing wear—a very lucky find.

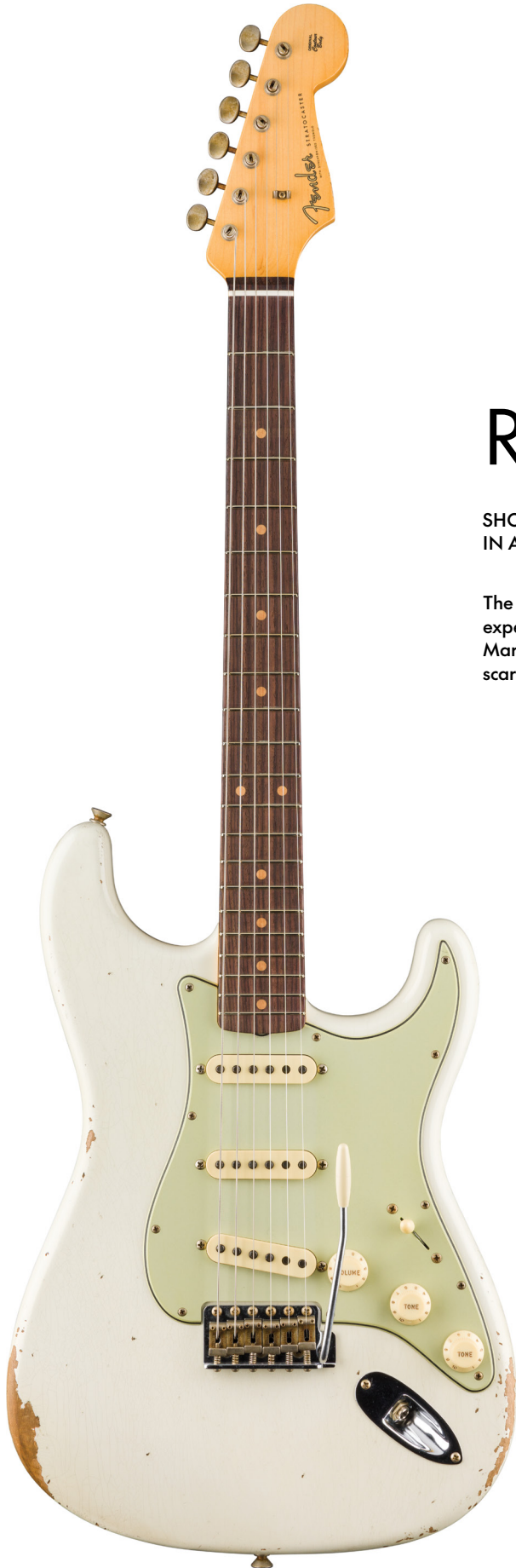

# RELIC®

SHOWN IN 1962 STRATOCASTER  
IN AGED OLYMPIC WHITE

The authentic worn-in wear of a guitar that has experienced many years of regular use in clubs and bars. Marks that tell a story, finish checking all over the body; scars, dings and dents from bridge to headstock.



# HEAVY RELIC®

SHOWN IN 1965 JAGUAR  
IN FADED OCEAN TURQUOISE

The heaviest of the relic treatments, designed to evoke decades of the most punishing play and touring. From serious dings and wear to intensely discolored hardware and finish; the true battle-hardened workhorse.



# SUPER HEAVY RELIC®

SHOWN IN LIMITED EDITION TELECASTER CUSTOM  
IN TWILIGHT SKY

The heaviest of our aging treatments, showcasing  
extreme wear and tear. Worn down to the wood in all the  
right places, broken in and comfortable like it was well-  
loved for decades.



LIMITED EDITION '59  
STRATOCASTER® HSS RELIC®  
ROSEWOOD, SHELL PINK METALLIC  
9235700072

# 04



SELECT  
**YOUR OPTIONS**

# TONewood OPTIONS

## BODY WOOD OPTIONS

---



### ALDER

A fantastic tonewood long used by Fender for their electric guitar bodies, alder is noted for bright, balanced and resonant tone with pronounced upper midrange, excellent sustain and sharp attack. It also features large, swirling grain patterns.



### ASH

Strong and dense, ash is a longtime Fender classic for electric instrument bodies. Notably resonant and sweet sounding, it's characterized by well-defined midrange and strong low end.

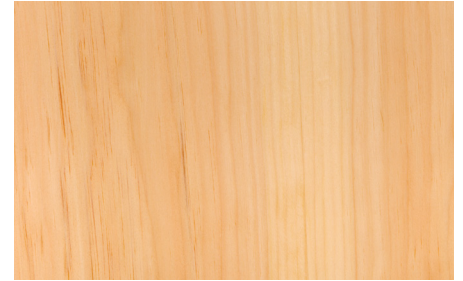

### PINE

Used by Fender in the early '50s, pine is a lightweight tonewood with well-balanced tone and beautiful resonance. Its grain pattern has defined swirls, making it a perfect choice for transparent finishes.

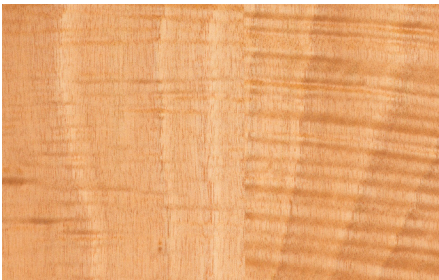

### OKUME

A warm-sounding tonewood with figured grain patterns that make it an excellent choice for a guitar body spread.

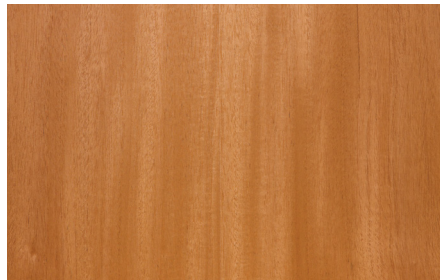

### MAHOGANY

A dense, dark tonewood that yields warm tone and midrange bite, mahogany is a great option that adds a unique and complex sonic and visual twist to your build.

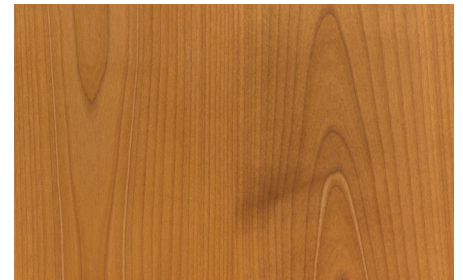

### ROASTED ALDER

The roasting process will darken the wood while keeping it very stable and durable. As with a slab of wood that has dried over the years, the properties change slightly and add to the richness and depth of tone.

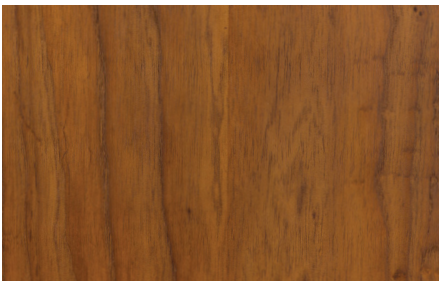

### ROASTED ASH

Strong and ultra-stable, a roasted ash body is a thing of beauty. Not only does the roasting process accentuate the figuring of the wood, it also crystallizes the sap, giving it the sound of old wood.

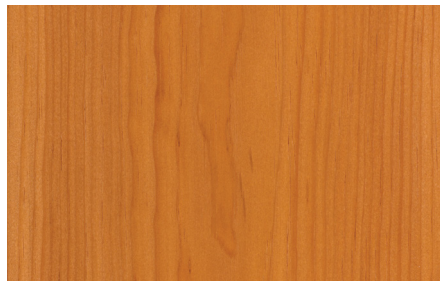

### ROASTED PINE

Roasting pine brings out all the best parts of the wood—it's full of rich harmonics with piano-like sustain. The dark caramel color and striking grain patterns match its complex and musical tonal qualities.

# QUILT/FLAME TOP OPTIONS



## QUILT MAPLE TOP

A beautifully figured wood, quilt maple works especially well with transparent and natural finishes that allow the flowing grain to show through.



## AA FLAME MAPLE TOP

AA flame maple features tiger-like striping in the wood grain. Many believe that this is caused by the tree swaying in the wind, the minerals in the ground and other ephemeral variables. We aren't positive about that, but we do know it provides a strikingly beautiful look to any instrument neck or body.



## AAA FLAME MAPLE TOP

AAA flame maple sorts a more intense concentration of figuring than AA Flame. The bold stripes are always a beautiful touch in natural and transparent finishes.



## SPALTED MAPLE

Spalted maple combines excellent strength and bright, crisp tone with incredibly unique and captivating figured lines and streaks to give your instrument an elegant look and sound.



## KOA

Beautiful and highly stable tone-wood prized for its resonance, workability and attractive figure.



## MAPLE BURL

Highly figured maple top used on our Artisan models with a gorgeous marbled swirl.

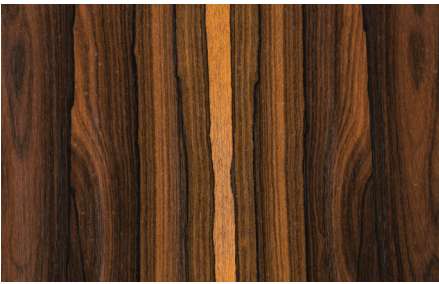

## ZIRCOTE

Known for its unique, swirly figuring with streaks of dark brown, zircote-topped instruments not only offer gorgeous aesthetics, but clean, crisp high end with fast attack when paired with ash or alder bodies.

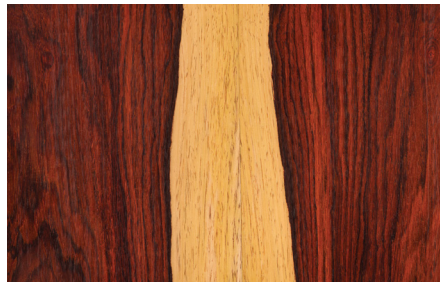

## COCOBOLO

Used in combination with mahogany, ash or alder bodies, cocobolo combines striking highly-figured, reddish-brown grain patterns with rich, warm resonance.

# NECK WOOD OPTIONS

---



## MAPLE NECK

Light in color, with a bright, chimey tone, maple is a favorite amongst many Fender players for its look, feel and tone.



## FLAME MAPLE

With its strong, vibrant figure, flame maple is one of our favorite ways to liven up the look of a maple neck.



## BIRDSEYE MAPLE

Small round figuring in the wood which produces small "birdseye" markings. Used on many Custom Shop guitars, a birdseye maple neck will add a unique and striking look to your guitar.



## ROASTED MAPLE NECK

Roasted maple creates an aged and dark look to the wood as well as making it more resonant and slightly lighter in weight.

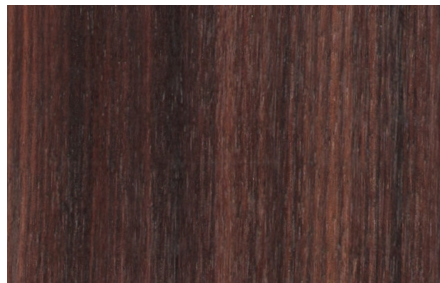

## ROSEWOOD NECK

Darker in color and warmer in tone than maple, rosewood can be specially sorted for a darker color. In 1959, all Fenders were outfitted with rosewood fingerboards, which was a significant departure from the look and tone of the previous maple boards.

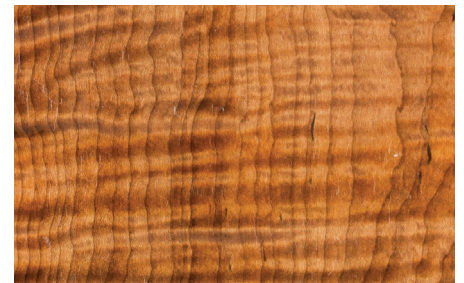

## ROASTED FLAME MAPLE

Roasting maple brings out the figure and creates a caramelized dark tiger striping.

# NECK TINT OPTIONS

---

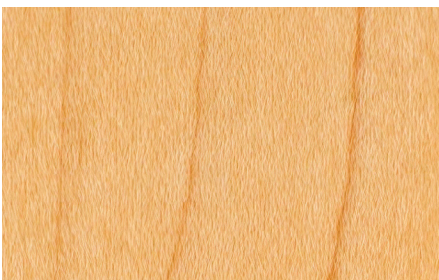

## LIGHT TINT



## MEDIUM TINT



## DARK TINT



SELECT FROM THESE  
**AVAILABLE FINISHES  
AND COLOR OPTIONS**

AVAILABLE FINISHES



• **YOUR COLOR**  
Example shown in Fiesta Red.



• **YOUR COLOR AGED**  
Adds a golden tint to simulate aging.



• **YOUR COLOR FADED**  
Creates the look of a color that has faded over time.

COLOR OPTIONS

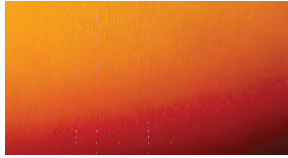

00 3 COLOR SUNBURST



01 WHITE BLONDE

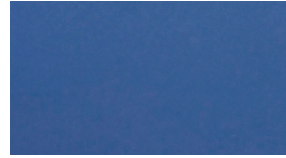

02 LAKE PLACID BLUE

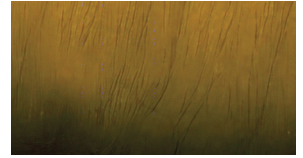

03 2 COLOR SUNBURST



04 DAPHNE BLUE

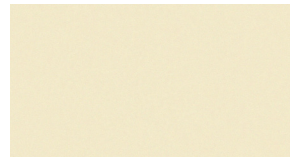

05 OLYMPIC WHITE

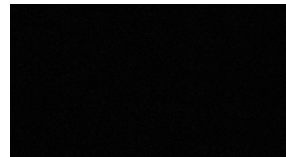

06 BLACK



07 VINTAGE BLONDE



08 OCEAN TURQUOISE



09 CANDY APPLE RED

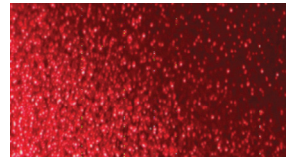

12 RED SPARKLE

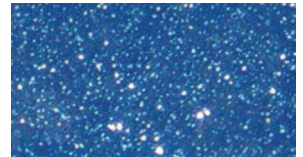

13 BLUE SPARKLE



15 HOT ROD RED

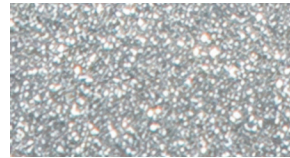

17 SILVER SPARKLE

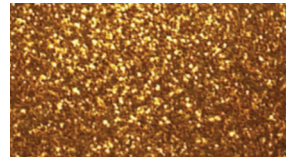

18 GOLD SPARKLE



19 SAGE GREEN METALLIC



20 AMBER



21 NATURAL

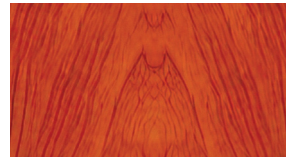

22 SUNSET ORANGE TRANS



23 PEARL WHITE



24 INCA SILVER



25 CHROME RED



26 VIOLET



27 SAPPHIRE BLUE TRANS



28 CRIMSON BURST

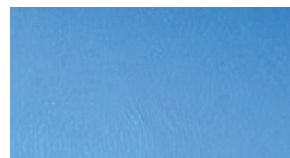

29 BLUE AGAVE



30 CHERRY SUNBURST



31 AGED CHERRY SUNBURST

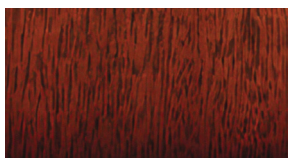

32 BROWN SUNBURST

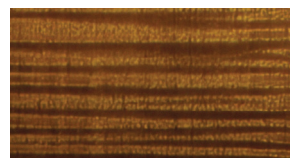

33 VIOLIN BURST



34 AGED NATURAL

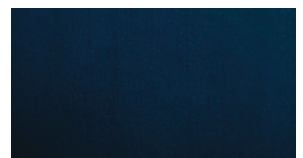

36 BLUE BURST

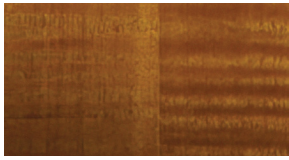

37 ANTIQUE BURST



38 CRIMSON TRANS



39 EBONY TRANS



40 FIESTA RED

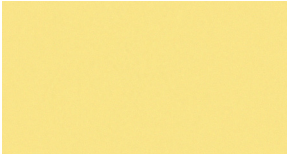

41 VINTAGE WHITE



42 MERCEDES BLUE



43 PEWTER



44 SHORELINE GOLD

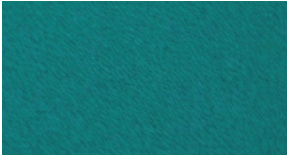

45 TEAL GREEN METALLIC



46 SHERWOOD GREEN MET.



47 SIENNA SUNBURST



48 TEAL GREEN TRANS



49 SEA FOAM GREEN



52 TOBACCO BURST



53 FIRE MIST GOLD



54 DAKOTA RED



55 FROST WHITE



56 SHELL PINK



57 SURF GREEN



58 TORINO RED



59 BLACK PEARL

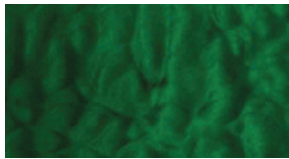

60 EMERALD GREEN TRANS

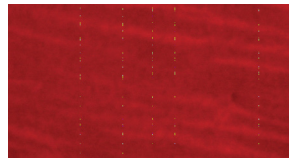

61 BING CHERRY TRANS



62 COBALT BLUE TRANS



63 GRAFFITI YELLOW



66 BURGUNDY MIST MET.



67 HONEY BLONDE



68 LIME GREEN



70 CADMIUM ORANGE

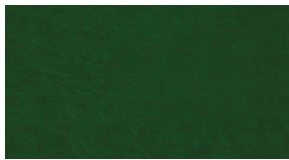

71 CANDY GREEN



72 SONIC BLUE

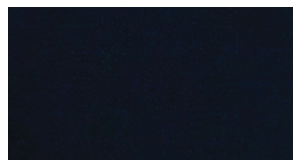

73 MIDNIGHT BLUE



74 AQUA MARINE METALLIC



75 MIDNIGHT WINE



76 MIDNIGHT PURPLE



77 FROST RED

39



78 AZTEC GOLD



79 FROST GOLD

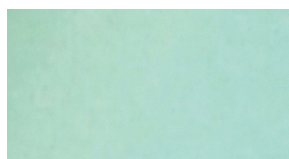

81 SURF PEARL



82 CANDY TANGERINE

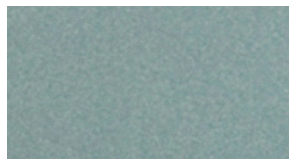

83 BLUE ICE METALLIC

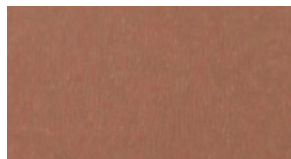

84 COPPER



85 BRIGHT AMBER MET.



86 BRIGHT SAPPHIRE MET.



87 COBALT BLUE METALLIC

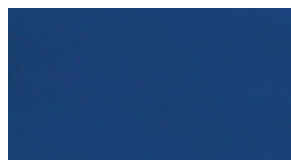

88 DESERT SUNSET



89 DESERT SAND

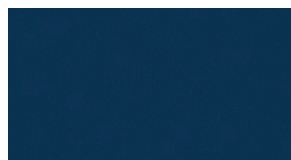

90 BALTIC BLUE



92 WALNUT



93 PURPLE METALLIC

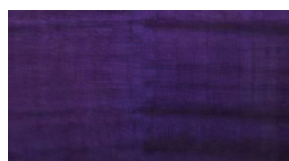

94 PURPLE TRANS

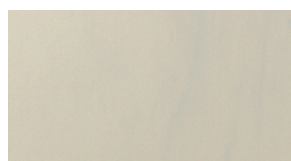

95 AGED VINTAGE WHITE



96 ORANGE



97 CHOCOLATE 3 TONE SB



98 HLE GOLD



99 NOCASTER BLONDE



BG BRITISH RACING GREEN



BT BUTTERSCOTCH BLONDE

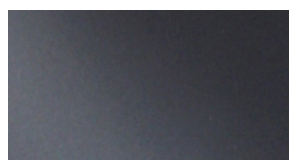

CF CHARCOAL FROST MET

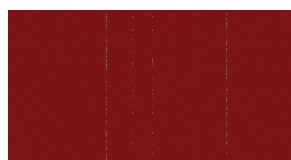

CR CIMARRON RED

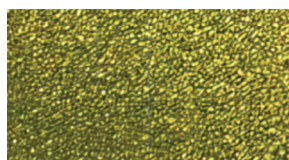

CS CHARTREUSE SPARKLE



DB DIRTY WHITE BLONDE



HB HONEY BURST

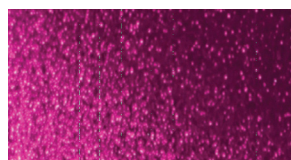

MS MAGENTA SPARKLE

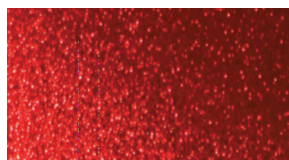

OS ORANGE SPARKLE



PS PURPLE SPARKLE



SR SEMINOLE RED



SS SEAFOAM GREEN SPARKLE



TT TAOS TURQUOISE



SELECT A  
**NECK SHAPE**

# GUITAR NECK SHAPES

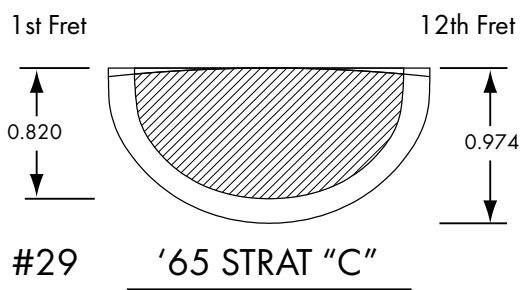
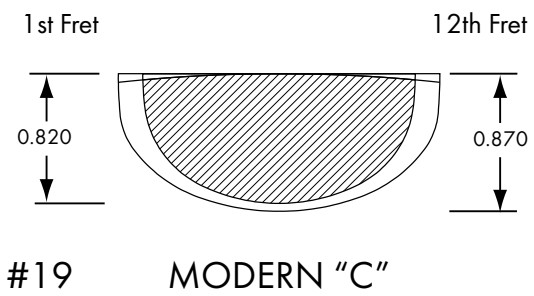
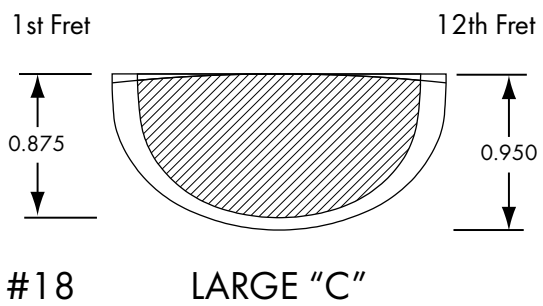
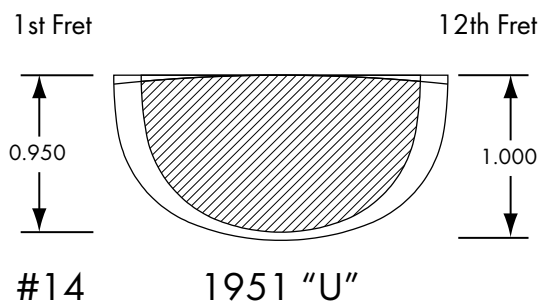
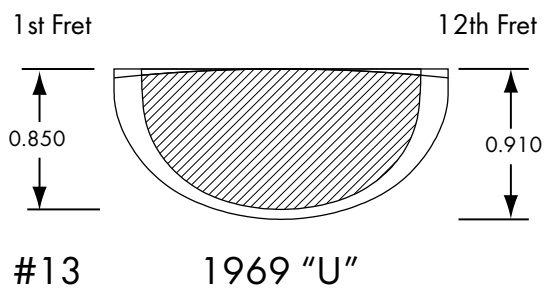
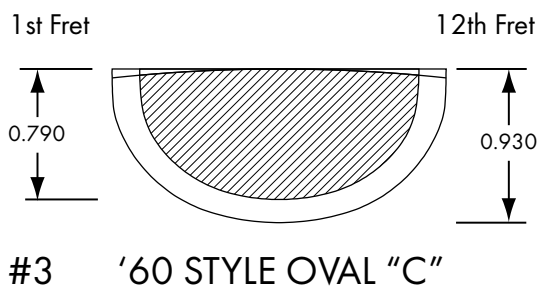
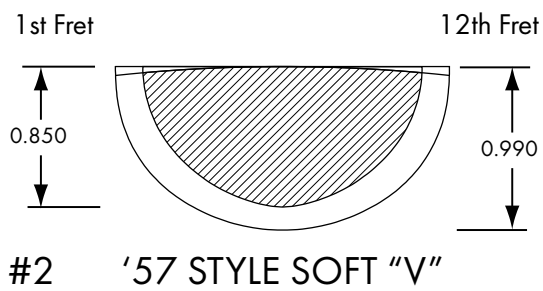
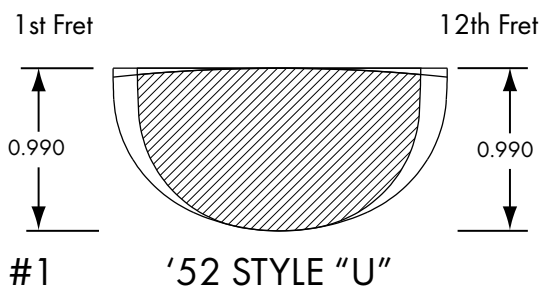

# GUITAR NECK SHAPES (CONT.)

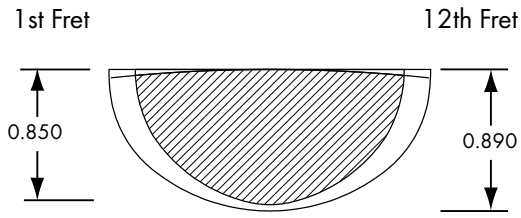

#20 MODERN "V"

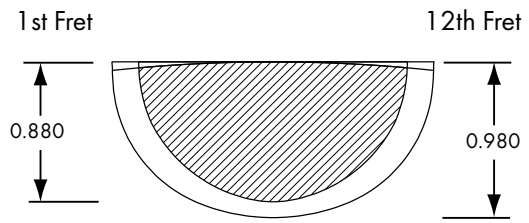

#23 10/56 "V"

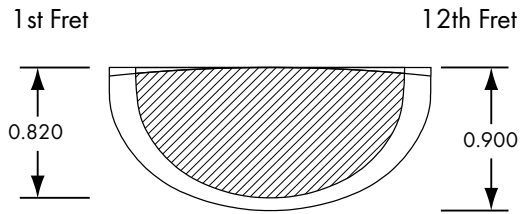

#36 JAGUAR /  
JAZZMASTER "C"

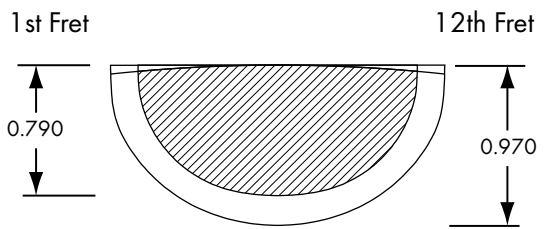

#28 '59 "C"

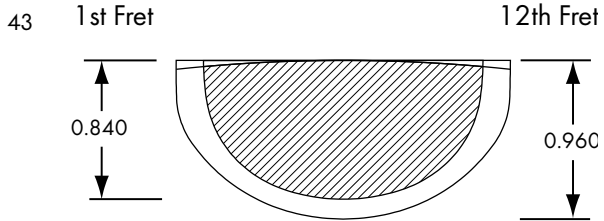

#51 '66 STRAT OVAL "C"

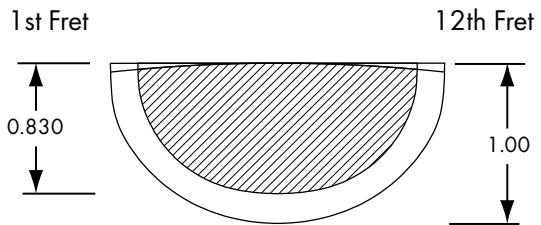

#59 '63 "C"

# BASS NECK SHAPES

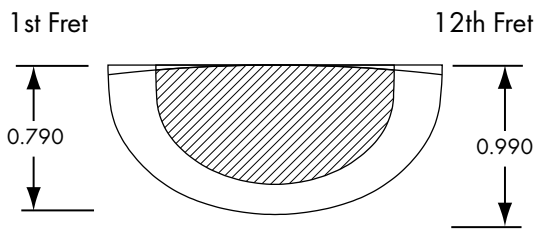

#8 '60 J BASS "U"

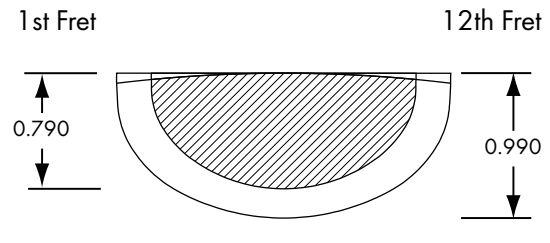

#7 '60 P BASS OVAL "C"

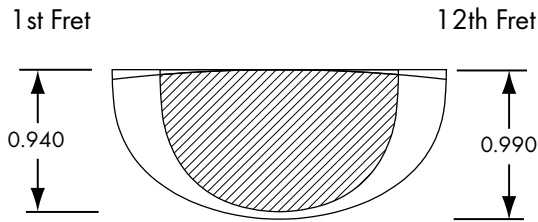

#12 '51 P BASS "U"

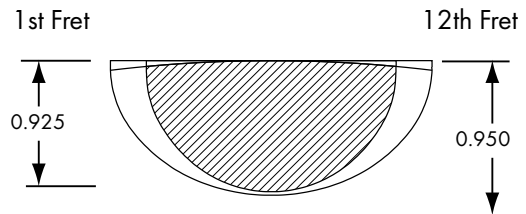

#30 '55 P BASS SOFT "V"

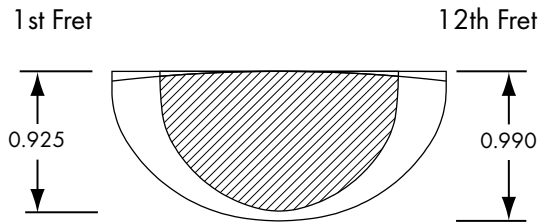

#6 '57 BASS SOFT "V"

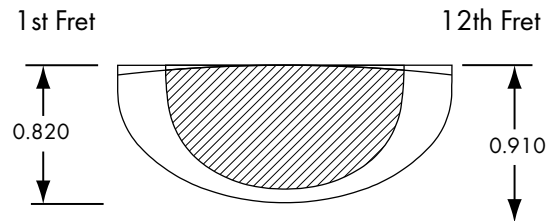

#26 CC JAZZ BASS  
4 STRING "C"

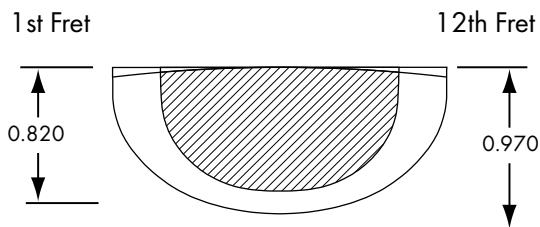

#40 '75 JAZZ BASS



## SELECT A FRET WIRE

Custom Shop frets are made from only the highest quality nickel and can be made in a variety of different heights and thicknesses. Larger frets tend to account for easier string bending. Smaller frets are “true to vintage” in many cases and facilitate easier chording.

Medium jumbo frets are designed to be the perfect marriage between small vintage frets and modern jumbo frets. Keep the following examples in mind when choosing the frets that you want on your guitar.

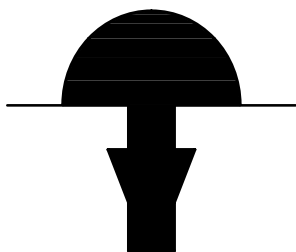

## VINTAGE 45085

H: 0.045"

W: 0.085"

Our smallest wire, slightly larger than Fender's original wire.

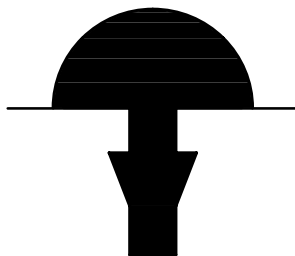

## MEDIUM VINTAGE 47095

H: 0.047"

W: 0.095"

Slightly lower than 6105.

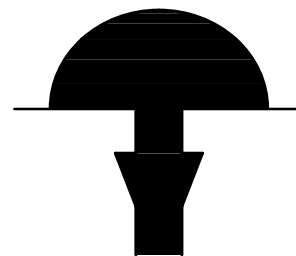

## MEDIUM JUMBO 6150

H: 0.047"

W: 0.104"

A popular middle of the road wire, not too wide, not too tall.

\*Also available in Stainless Steel on Master Built guitars only.

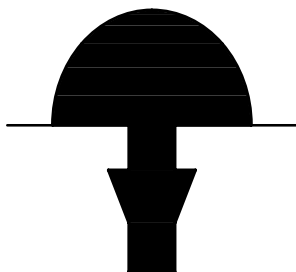

## NARROW TALL 6105

H: 0.055"

W: 0.095"

Our most popular wire. A good alternative if vintage wire feels too small for you.

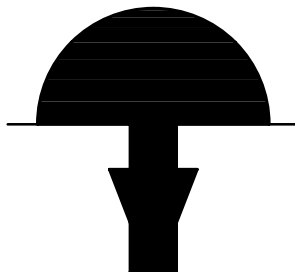

## JUMBO 6100

H: 0.057"

W: 0.110"

Our largest wire that gives an almost scalloped feel.

\*Also available in Stainless Steel on Master Built guitars only.



## SELECT A PICKUP OPTION

**HAND-WOUND:** True to Fender history prior to 1965, hand-wound or “scatter-wound” pickups are distinctly unique in character. Each pickup has its own subtle nuances and personalized character which is what made the original Fender pickups so sought after and prized.

**MACHINE-WOUND:** Each pickup is consistent and even in winds making each one sound and respond relatively the same. Though most of the Custom Shop pickups are hand-wound, some players prefer the consistency of machine-wound pickups, so we are happy to offer both options.

# STRATOCASTER PICKUPS



## '50S STRAT

Crafted to faithfully replicate the cutting tones reminiscent of 1950s Stratocaster® guitars. Alnico 5 magnets, vintage stagger and formvar wire.



## FAT '50S STRAT

1950s Stratocaster sound you know and love. Hot-rodged wiring design delivers enhanced bass response and an extra shot of 21st-century attitude.



## '60S STRAT

Classic 1960s design with alnico 2 magnets, formvar wire and a vintage stagger. Strat sound with glistening highs and warm, punchy lows.



## TEXAS SPECIAL™ STRAT

Characterized by their midrange chirp, crystalline highs and tight bass, Fender Texas Special™ Strat pickups feature an overwound single-coil construction that produces big Texas-blues tone.



## DUAL-MAG STRAT

Vintage style calibrated pickup set with unbeveled alnico 5 magnets on the bass side and beveled alnico 2 magnets on the treble. The two magnet types create balance and consistency in tone and allow for improved clarity string to string.



## EL DIABLO STRAT

Overwound and dipped in the special sauce for a big open sound. Slightly hotter than the Ancho Poblanos with calibrated alnico 5 pickups with custom low G (middle and neck) and flush with high D (bridge) pole pieces.



## ANCHO POBLANO STRAT

Simmered in a secret Custom Shop sauce and then individually calibrated from neck to bridge. Uniquely overwound by hand for a wide range of high-output tones—from blistering-hot output to sizzling vintage warmth—with plenty of tonal flexibility.



## VINTAGE NOISELESS™ STRAT

Produce all the brilliant clarity, definition and harmonic attributes of vintage single-coil Strat tone without the hum.



## TOMATILLO STRAT

Cousins to the Ancho Poblanos, dipped in the same secret sauce. Alnico 2 magnets will simulate what an older alnico 5 might sound like today for a sweeter, more flavorful tone.

# TELECASTER PICKUPS



'51 TELE/NOCASTER

Created with the original design in mind to accurately mimic the twang and shimmer of the originals. These period-correct single-coil pickups impart tight low end and clear, balanced midrange.



'51 LOADED NOCASTER

Extra winds of #43 gauge enamel wire give these pickups fat, juicy tone. Perfect for driving a preamp into gritty overdrive, these high-output pickups burn with vintage-inspired tone, thanks to the bridge pickup's alnico 3 magnets and neck pickup's alnico 5 magnets.



'56/'57 TELECASTER

An accurate recreation of the Tele pickups we constructed during '56/'57. These pickups have all the grunt and snarl of the originals, thanks to the unbeveled, staggered alnico 5 magnets and enamel-coated wire.



'63 TELE

A true replication of the original '63 Tele Pickups with all the bite and warmth to spare. Alnico 2 magnets, vintage stagger and enamel wire.



'67 TELE

Lower output Tele pickups with grey bobbins and copper baseplate with a vintage stagger, alnico 5 magnets and enamel wire for crystal clear Tele twang.



TWISTED TELE

High-output Telecaster guitar tone with a dash of sparkling Stratocaster® guitar character.



TEXAS SPECIAL TELE

Fender Custom Shop Texas Special Tele pickups are built to produce blistering hot output, along with noticeable presence and midrange.

49

# BASS PICKUPS



'64 JAZZ BASS

These vintage-style pickups produce warm, clear and articulate tone, with great low-end definition, up-front midrange punch and singing high end.



'75 JAZZ BASS

Vintage bobbin construction, Alnico 5 magnets, flush mounted pole pieces and enamel wire provide warm tones, enhanced dynamics and even string response.



NOISELESS JAZZ BASS

Fender Noiseless Jazz Bass pickups produce all the brilliant clarity, definition and harmonic attributes of a vintage Jazz Bass without the hum.



HAND-WOUND P-BASS

Alnico 5 magnets and enamel wire, hand-wound just like we did in the '50s and '60s. The most iconic bass pickup in the world.

# HUMBUCKER PICKUPS



## SHAWBUCKER™

Full of multi-dimensional tone with well-defined overtones, this open-coil pickup complements and balances your guitar's natural voice while playing well with other pickup designs.



## CUNIFE® WIDE RANGE

The look of the famous Fender pickup design of the early 1970s with period correct magnets, as used on original-era Telecaster Thinline, Telecaster Custom and Telecaster Deluxe models.

# P-90 PICKUPS



## CSP-90

This classic design sings with pure Fender tone, bringing clear articulation to every note you play, from delicately nuanced cleans to snarling, spitting means.





## SELECT A WIRING OPTION

# STRATOCASTER WIRING

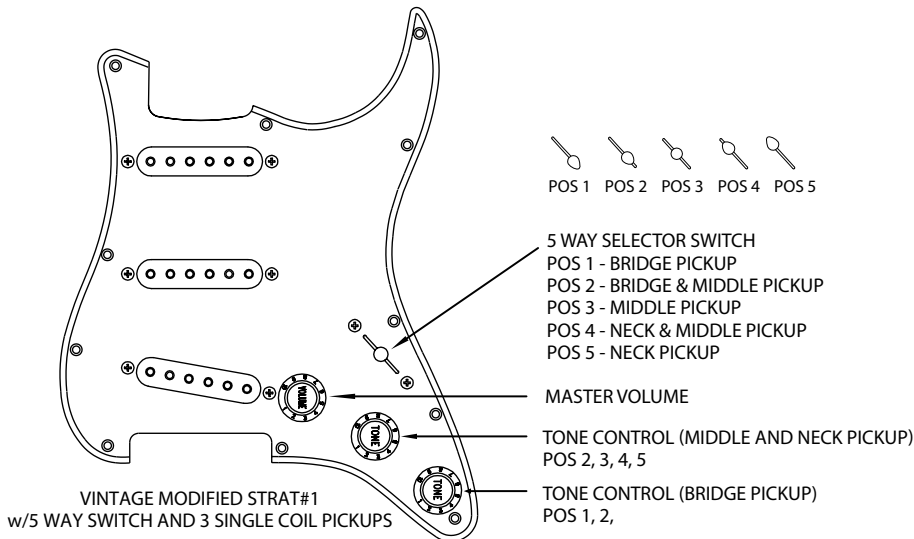
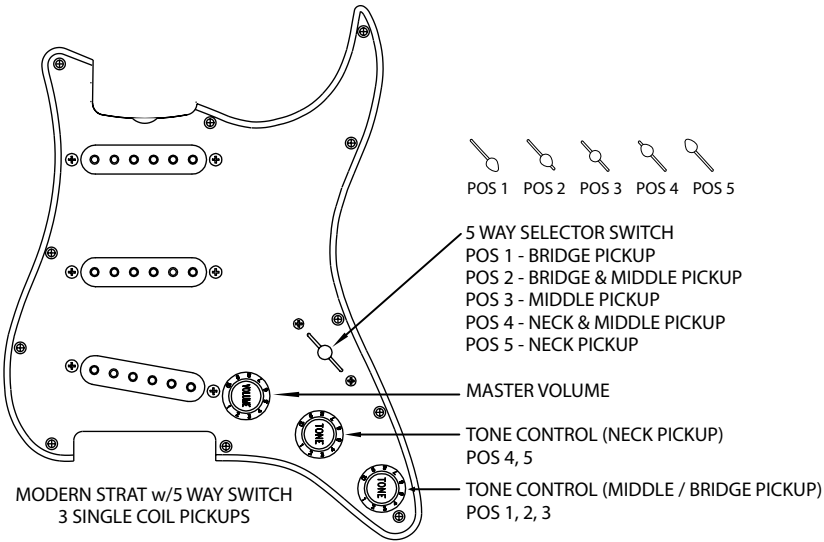
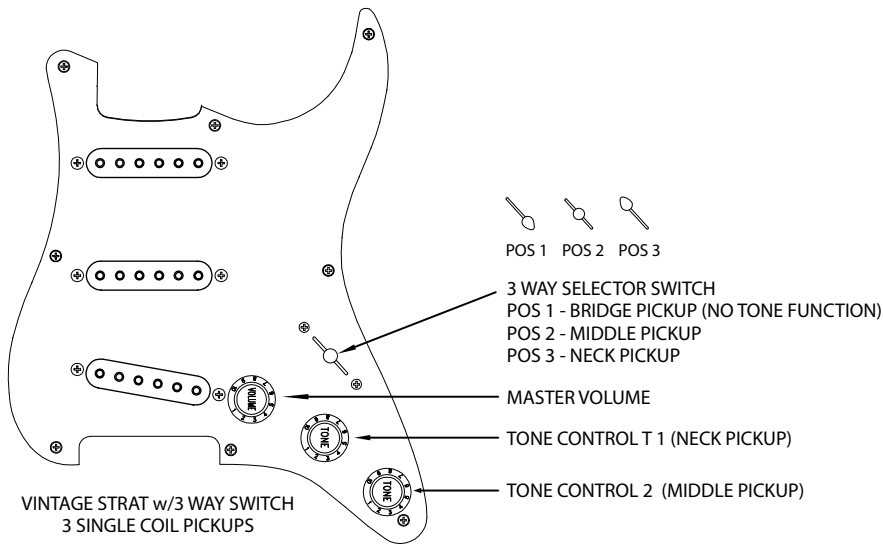

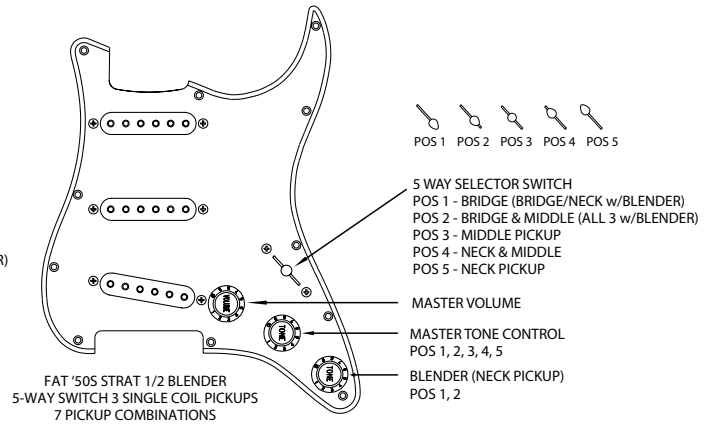
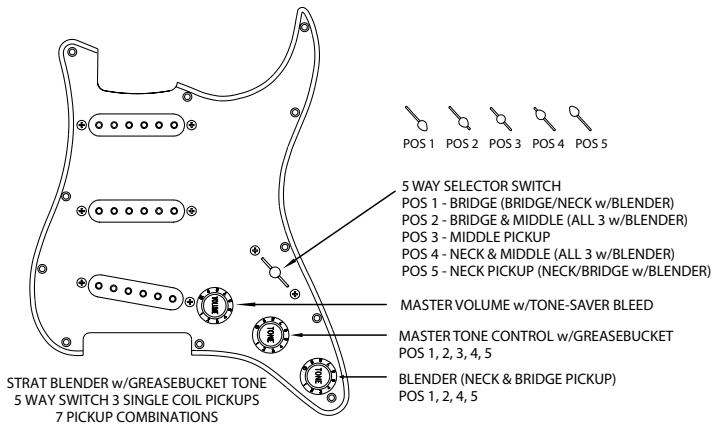
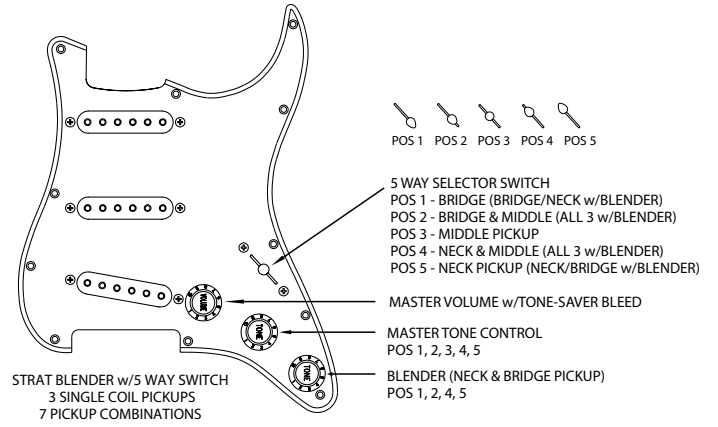
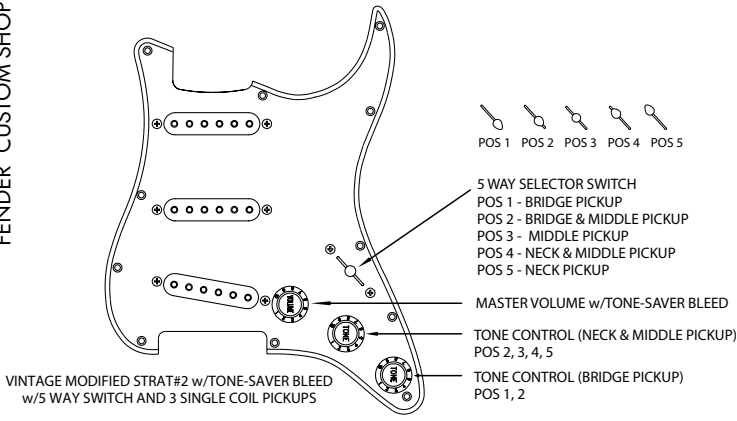

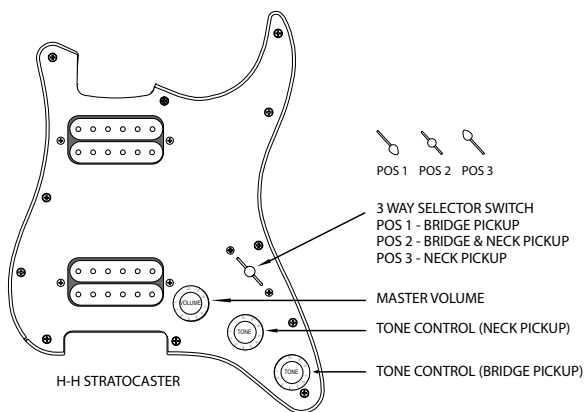
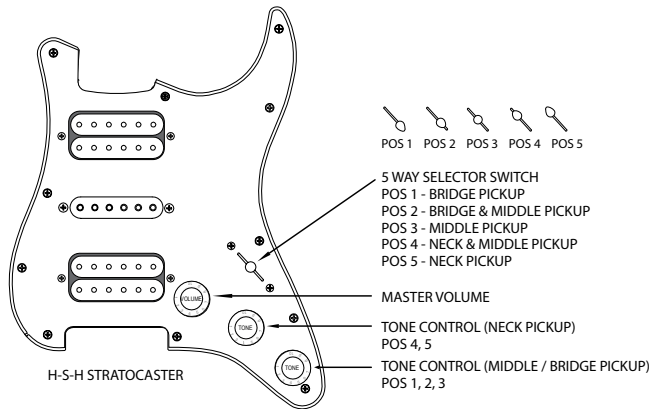
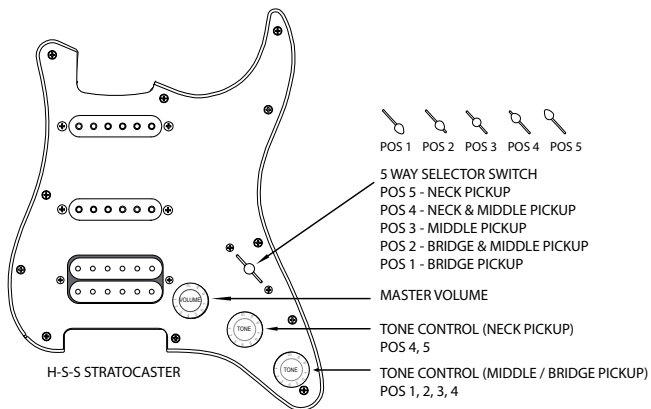

# TELECASTER WIRING

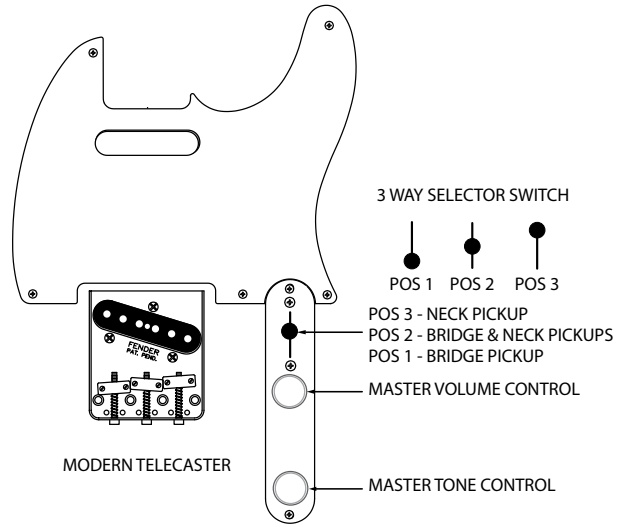
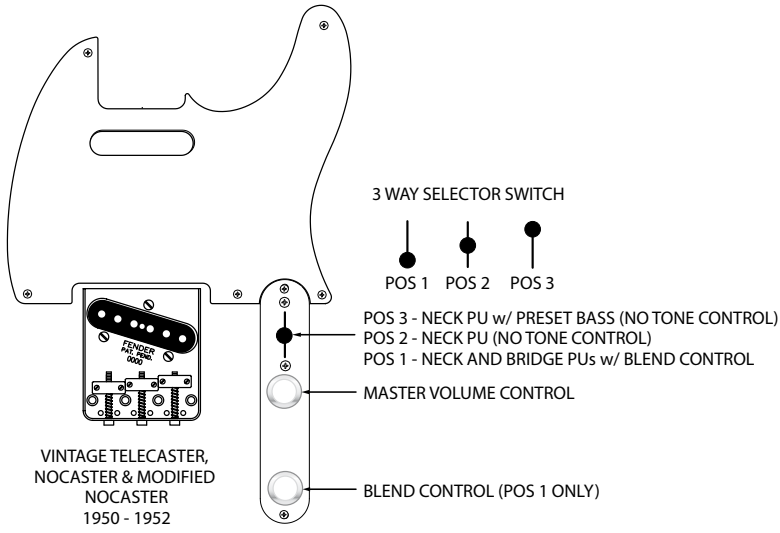

55

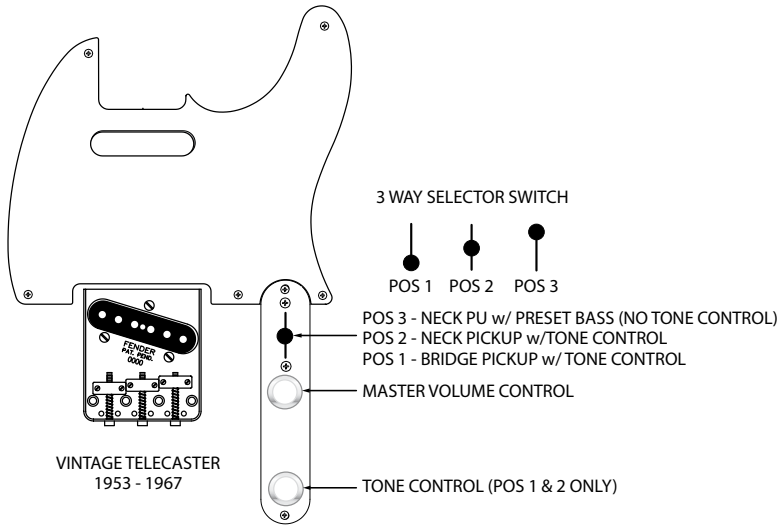

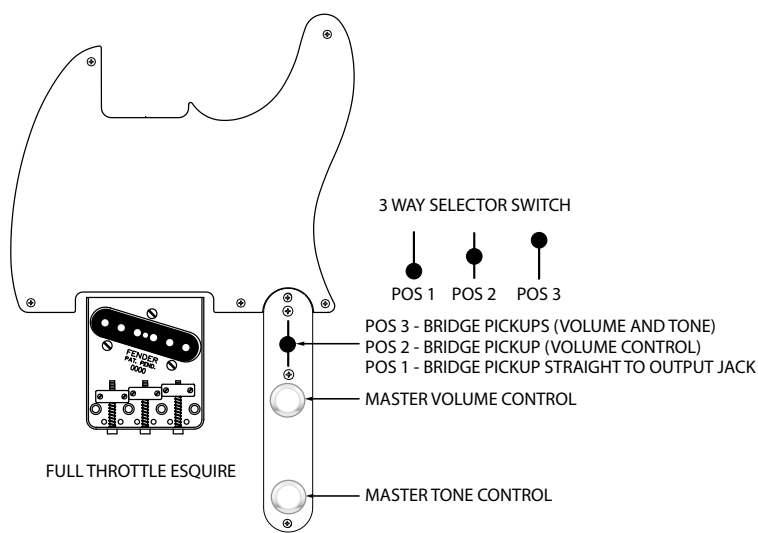
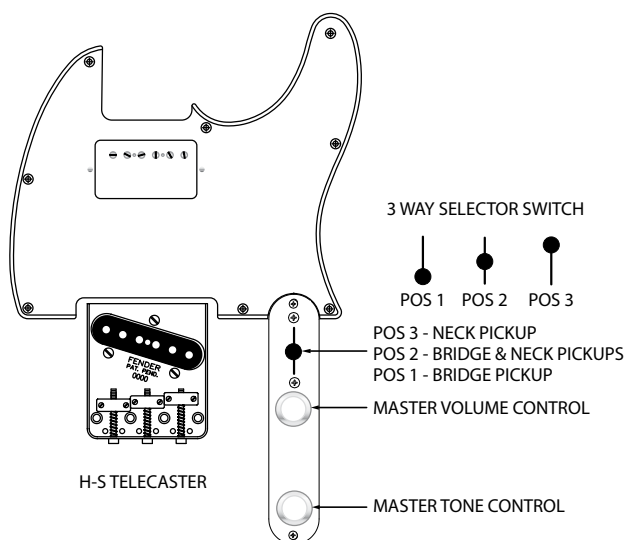
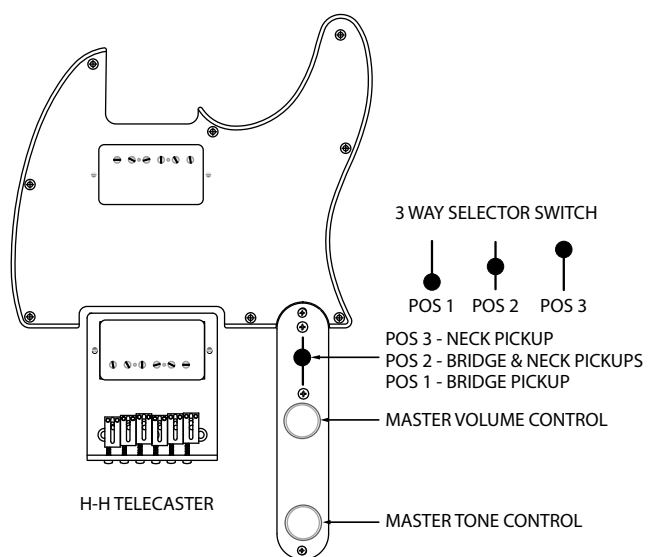
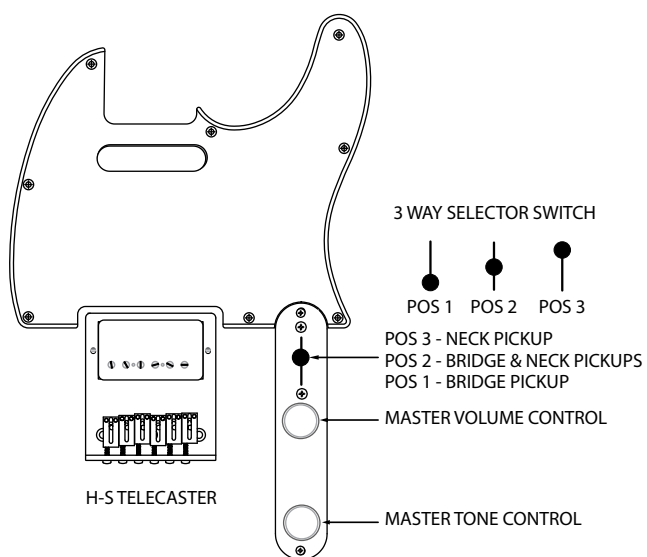

# PRECISION BASS WIRING

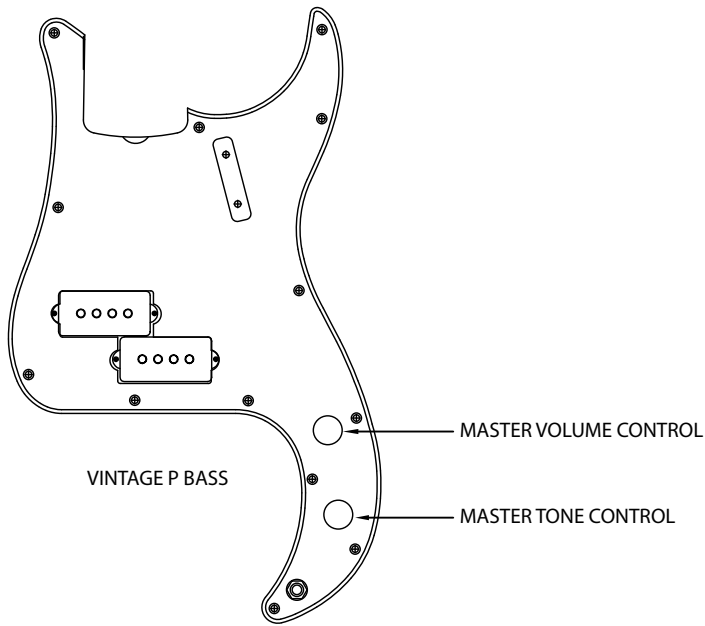

# JAZZ BASS WIRING

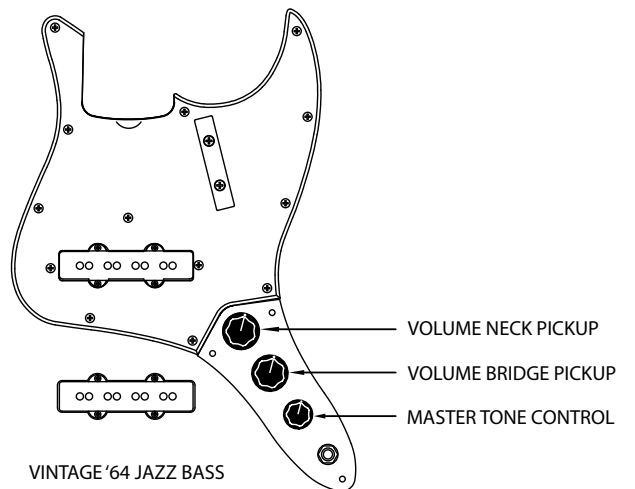
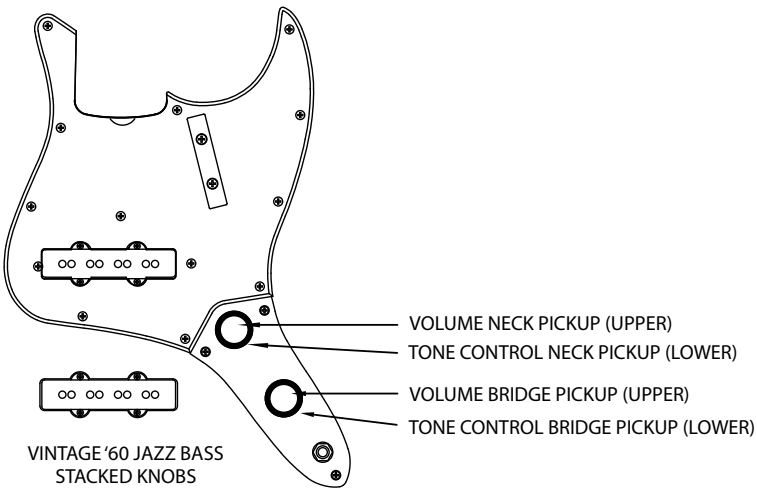



SELECT  
**HARDWARE OPTIONS**

# STRATOCASTER BRIDGES

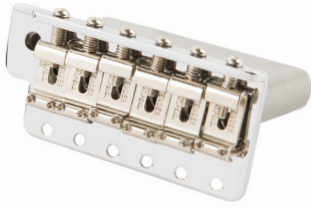

## VINTAGE SYNCHRONIZED TREMOLO

Original Stratocaster tremolo made using original die-cast moulds and punch presses.

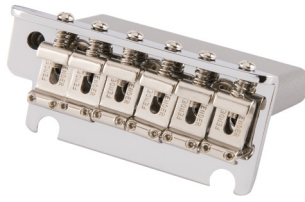

## 2-POINT CLASSIC PLAYER TREMOLO

Polished steel two-point synchronized tremolo bridge assembly.



## 2-POINT CUSTOM CLASSIC TREMOLO

Polished steel two-point synchronized tremolo bridge assembly with polished-steel block saddles.

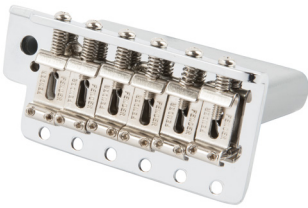

## RSD STRAT TREMOLO

Vintage style with improved pivot geometry, plating tolerances, string spacing and arm tension adjustment.

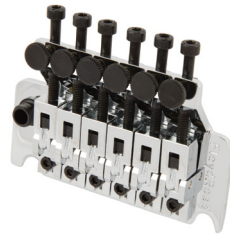

## FLOYD ROSE® ORIGINAL

Double-locking tremolo bridge, recessed for pick hand comfort providing laser-accurate intonation and ultra-stable tuning when combined with the Floyd Rose R3 locking nut.

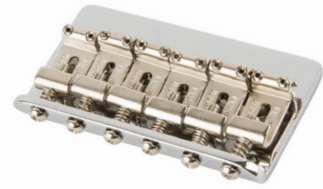

## VINTAGE HARD-TAIL

Original hard-tail Strat bridge made using original die cast moulds and punch presses.

# TELECASTER BRIDGES

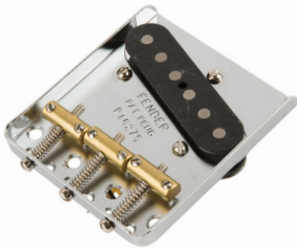

## '51-'53 TELECASTER - BRASS SADDLES

Telecaster ashtray bridge plate with original tooling marks, serial number and three brass saddles.

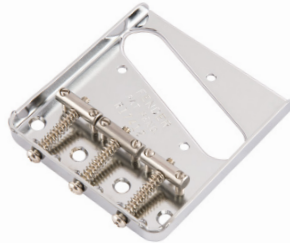

## '54-'57 TELECASTER - STEEL SADDLES

Period correct ashtray bridge plate and steel barrel saddles for bright Tele® twang.

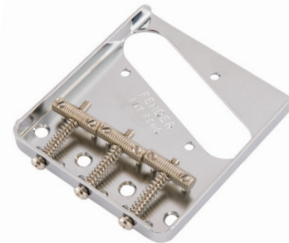

## '60 & UP TELECASTER THREADED SADDLES

Period correct ashtray bridge plate and threaded steel saddles for bright Tele® twang.

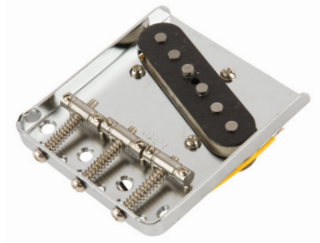

## '67 TELE-SLOTTED STEEL SADDLES

Vintage style ashtray bridge plate with notched steel saddles.



## RSD TELE

Low profile bridge plate, compensated brass saddles with refined look and feel.

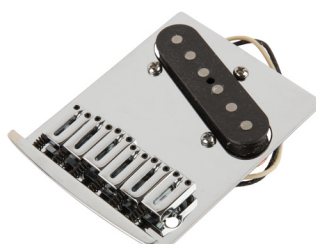

## CUSTOM DELUXE TELE

Modern six-saddle bridge assembly with string-through-body plate and polished steel saddles.

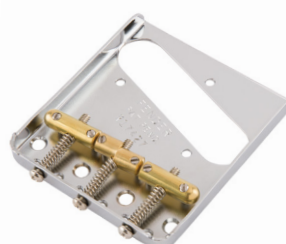

## VINTAGE RSD TELE

Vintage style ashtray bridge plate with compensated RSD saddles.

# BASS BRIDGES

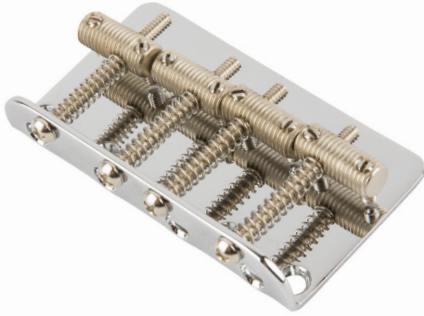

## VINTAGE THREADED SADDLES

Genuine Fender bass bridge assembly with nickel-plated steel bridge plate and four threaded barrel saddles.

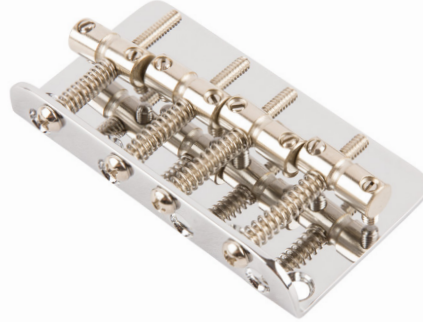

## VINTAGE GROOVE SADDLES

Vintage Fender bass bridge assembly with nickel-plated steel bridge plate and four grooved barrel saddles.

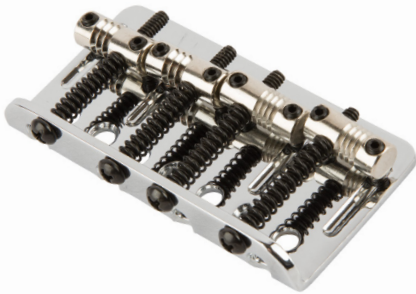

## AMERICAN DELUXE BASS BRIDGE

Chrome plated steel bridge plate with partially threaded stainless steel saddles and string through body or top load option.



## RSD BASS

Hi-Mass bridge constructed from a solid brass billet with threaded steel saddles.

# JAZZMASTER/JAGUAR BRIDGES



## RSD J-BRIDGE

Two movable brass saddles bolted to a cold rolled steel base provides an articulate tone with more punch, attack and continuity than its predecessor. The J-Bridge lets the sound of the guitar ring through and gives a stronger primary note.

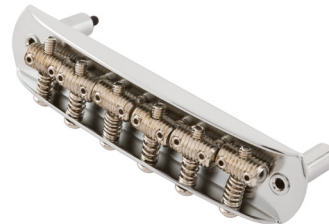

## VINTAGE JAZZ/JAG

Nickel-plated bridge assembly with six adjustable threaded saddles.

# TUNING MACHINES



SCHALLER F



MODERN AMERICAN STANDARD



MODERN LOCKING



VINTAGE LOCKING



VINTAGE STYLE

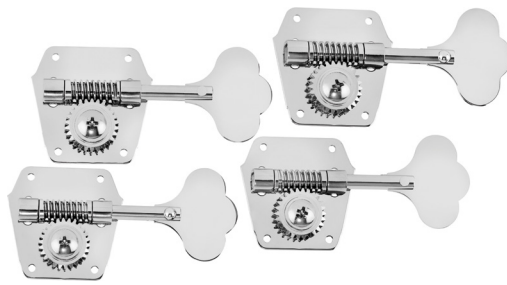

VINTAGE STYLE BASS

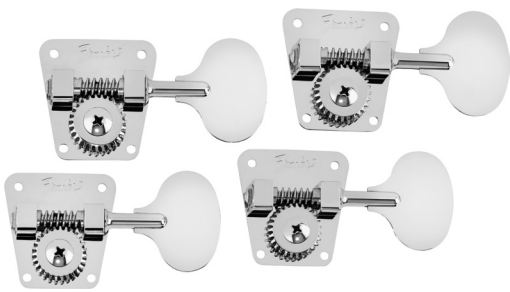

VINTAGE STYLE BASS "LOLLIPOP"



MODERN BASS

# PICKGUARDS



3-PLY WHITE

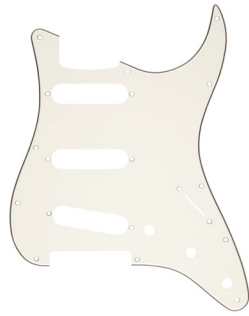

3-PLY EGGSHELL

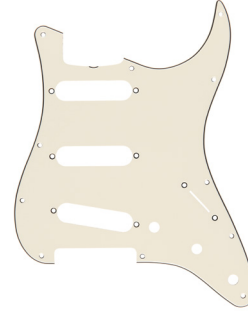

3-PLY PARCHMENT



3-PLY MINT GREEN



ANODIZED GOLD



4-PLY BROWN SHELL



BLACK



4-PLY BLACK PEARLOID



4-PLY WHITE PEARLOID

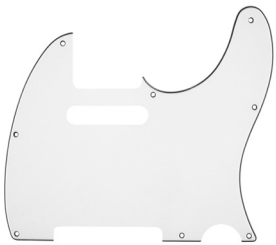

3-PLY WHITE

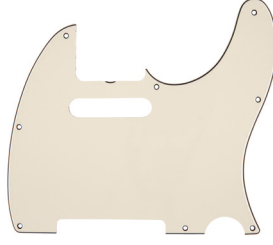

3-PLY PARCHMENT

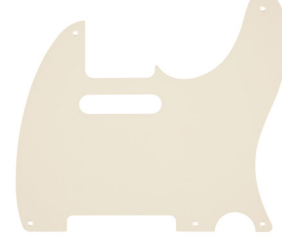

1-PLY PARCHMENT



3-PLY BLACK



BLACK PHENOLIC

# SWITCH TIPS, CONTROL KNOBS AND PICKUP COVERS

## SWITCH TIPS



WHITE



EGGSHELL



PARCHMENT



VINTAGE WHITE



AGED WHITE



BLACK

## CONTROL KNOBS



WHITE



EGGSHELL



PARCHMENT



VINTAGE WHITE



AGED WHITE



BLACK

## PICKUP COVERS



WHITE



EGGSHELL



PARCHMENT

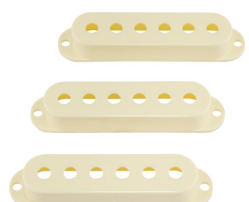

VINTAGE WHITE



AGED WHITE



BLACK

# DESIGN GUIDE ORDER FORM

## BUILD LEVEL (SELECT ONE)

- MASTERBUILT  
SELECT BUILDER \_\_\_\_\_
- ADD PREMIUM BUILDER
- CUSTOM-BUILT

## BASE MODEL

### STRATOCASTER® (START AT PG 17)

- 1955 STRATOCASTER® (ASH)
- 1956 STRATOCASTER® (ALDER)
- OTHER 1950'S STRATOCASTER® (ALDER) \_\_\_\_\_
- 1960 STRATOCASTER® (ALDER)
- 1963 STRATOCASTER® (ALDER)
- 1965 STRATOCASTER® (ALDER)
- 1966 STRATOCASTER® (ALDER/LARGE HEADSTOCK)
- 1969 STRATOCASTER® (ALDER/LARGE HEADSTOCK)
- OTHER 1960'S STRATOCASTER® (ALDER) \_\_\_\_\_
- ANVIL FLIGHT CASE OPTION (STRAT®)

### NOCASTER®/TELECASTER®/ESQUIRE® (START AT PG 19)

- 1951 NOCASTER® (ASH)
- 1952 TELECASTER® (ASH)
- OTHER 1950'S TELECASTER® (ASH) \_\_\_\_\_
- 1960 TELECASTER® (ALDER)
- 1960 TELECASTER® CUSTOM (ALDER)
- 1963 TELECASTER® (ALDER)
- 1967 TELECASTER® (ALDER)
- OTHER 1960'S TELECASTER® (ALDER) \_\_\_\_\_
- 1959 ESQUIRE® (ASH)
- OTHER YEAR ESQUIRE® \_\_\_\_\_ (THRU '69)
- THINLINE TELECASTER® (ASH)
- ANVIL FLIGHT CASE OPTION (TELE®)

### JAZZMASTER®/JAGUAR®/BASS VI (START AT PG 23)

- 1962 JAZZMASTER® (ALDER)
- OTHER YEAR JAZZMASTER® (ALDER) \_\_\_\_\_ (THRU '66)
- 1962 JAGUAR® (ALDER)
- OTHER YEAR JAGUAR® (ALDER) \_\_\_\_\_ (THRU '65)
- BASS VI (ALDER)

### FENDER BASS (START AT PG 21)

- 1955 PRECISION BASS® (ASH)
- 1959 PRECISION BASS® (ALDER)
- 1960 PRECISION BASS® (ALDER)
- OTHER YEAR PRECISION BASS® (ALDER) \_\_\_\_\_ (THRU '65)
- 1964 JAZZ BASS® (ALDER)
- OTHER YEAR JAZZ BASS® (ALDER) \_\_\_\_\_ (THRU '65)
- 1975 JAZZ BASS® (ASH)
- OTHER 1970'S JAZZ BASS® (ASH) \_\_\_\_\_ (THRU '74)

### AGING STYLE (START AT PG 25)

- NOS (NEW OLD STOCK)
- TIME CAPSULE (FLASH-COAT NOS/CC HDW)
- CLOSET CLASSIC
- CLOSET CLASSIC/NOS HDW
- DLX CLOSET CLASSIC
- JOURNEYMAN RELIC®
- JOURNEYMAN RELIC®/CLOSET CLASSIC HDW
- RELIC®

- RELIC®/CLOSET CLASSIC HDW
- HEAVY RELIC®
- HEAVY RELIC®/CLOSET CLASSIC HDW
- SUPER HEAVY RELIC®

## CUSTOM OPTIONS

### CONSTRUCTION

- LEFT HANDED
- CHAMBERED BODY
- HOLLOW BODY W/ F-HOLE (WITH ARM CONTOUR)
- BOUND BODY TOP (NO ARM CONTOUR)
- BOUND BODY TOP & BACK (NO CONTOURS)
- BOUND FINGERBOARD
- REVERSE HEADSTOCK
- CONTOURED NECK HEEL
- REVERSE ANGLE BRIDGE PICKUP ROUT

### BODY WOOD

- BASE MODEL BODY WOOD
- ALDER
- ASH
- EASTERN WHITE PINE
- OKOUME
- 2-PIECE FIJI MAHOGANY
- ROASTED ALDER
- ROASTED ASH
- ROASTED PINE
- SORT FOR LIGHT WEIGHT BODY WOOD
- OTHER BODY WOOD \_\_\_\_\_

### BODY WOOD/EXOTIC TOP

- FLAME MAPLE TOP 2A
- QUILTED MAPLE TOP 2A
- SPALTED MAPLE TOP
- MAPLE BURL TOP
- BUCKEYE BURL TOP
- ZIRICOTE TOP
- COCOBOLO TOP
- FIGURED KOA TOP 4A
- OTHER EXOTIC TOP \_\_\_\_\_

### BODY COLOR (SELECT FROM PAGE 33)

- SINGLE COLOR # \_\_\_\_\_
- COLOR OVER COLOR # \_\_\_\_\_ O # \_\_\_\_\_
- SPARKLE COLOR
- PINK PAISLEY (TOP)
- PINK PAISLEY (TOP & BACK)
- BLACK PAISLEY (TOP)
- BLACK PAISLEY (TOP & BACK)
- BLUE FLOWER (TOP)
- BLUE FLOWER (TOP & BACK)

### BODY FINISH

- BASE MODEL FINISH
- NITRO LACQUER
- NITRO LACQUER / WLS UNDERCOAT
- FLASH COAT LACQUER
- URETHANE

# CUSTOM OPTIONS (CONTINUED)

## NECK WOOD

- BASE MODEL NECK WOOD (FLAT SAWN MAPLE)
- RIFT SAWN MAPLE
- QUARTERSAWN MAPLE
- FLAME MAPLE 2A
- FLAME QUARTERSAWN MAPLE 2A
- FLAME MAPLE 3A
- BIRDSEYE MAPLE 2A
- BIRDSEYE MAPLE 3A
- ROASTED RIFT SAWN MAPLE
- ROASTED QUARTERSAWN MAPLE
- ROASTED FLAME MAPLE 3A
- ROASTED BIRDSEYE MAPLE 3A
- INDIAN ROSEWOOD
- OTHER NECK WOOD \_\_\_\_\_

## NECK TINT

- NO TINT
- LIGHT TINT
- MEDIUM TINT
- DARK TINT

## NECK FINISH

- BASE MODEL FINISH
- NITRO LACQUER
- SATIN LACQUER
- FLASH COAT LACQUER
- GLOSS URETHANE
- SATIN URETHANE
- MATCHING PAINTED HEADCAP

## NECK SHAPE

- BASE MODEL NECK SHAPE\*
- CUSTOM NECK SHAPE # \_\_\_\_\_ (START AT PAGE 36)
- CUSTOM DIMS: 1ST \_\_\_\_\_ 12TH \_\_\_\_\_

## FINGERBOARD WOOD

- BASE MODEL FINGERBOARD WOOD
- 1-PIECE MAPLE NECK
- FLAT-LAM (SLAB) MAPLE
- ROUND-LAM MAPLE
- FLAT-LAM (SLAB) ROSEWOOD
- ROUND-LAM ROSEWOOD
- SORT FOR DARK ROSEWOOD
- AFRICAN BLACKWOOD
- EBONY

## FINGERBOARD RADIUS

- BASE MODEL FINGERBOARD RADIUS
- 7.25" RADIUS
- 9.5" RADIUS
- 12" RADIUS
- 7.25" TO 9.5" VINTAGE COMPOUND RADIUS
- 7.25" TO 12" COMPOUND RADIUS
- 9.5" TO 12" COMPOUND RADIUS
- 9.5" TO 14" COMPOUND RADIUS
- 9.5" TO 16" COMPOUND RADIUS (BASS ONLY)
- SCALLOPED FINGERBOARD

## WIDTH AT NUT

- BASE MODEL WIDTH AT NUT
- 1.625"
- 1.650"
- 1.685"
- 1.6875"

## NUT MATERIAL

- BASE MODEL NUT MATERIAL
- MICARTA
- BONE
- GRAPHITE
- LSR ROLLERNUT - 1.6875" NUT (RH ONLY)

## NUMBER OF FRETS

- BASE MODEL NUMBER OF FRETS
- 22 FRETS (STRAT®/TELE®)

## FRET WIRE

- BASE MODEL FRET WIRE
- VINTAGE STYLE
- MEDIUM VINTAGE 47095
- NARROW TALL 6105
- MEDIUM JUMBO 6150
- JUMBO 6100
- OTHER FRET WIRE \_\_\_\_\_

## POSITION & SIDE MARKERS

- BASE MODEL DOT MATERIAL
- BLACK
- WHITE
- VINTAGE CLAY
- MOP WHITE
- ABALONE
- BLACK OPAQUE BLOCK INLAY
- BLACK POLY PEARL BLOCK INLAY
- WHITE POLY PEARL BLOCK INLAY
- WHITE MOP BLOCK INLAY

## 12<sup>TH</sup> FRET DOT SPACING

- BASE MODEL DOT SPACING
- WIDE 12TH FRET DOT SPACING
- NARROW 12TH FRET DOT SPACING

## TRUSS ROD

- BASE MODEL TRUSS ROD
- BI-FLEX™ (STRAT®/TELE® HEADSTOCK ADJUST)

## HARDWARE COLOR

- GOLD

## NECK PLATE

- BASE MODEL NECK PLATE (R SERIAL)
- V-LOGO NECK PLATE
- F-LOGO NECK PLATE
- F-LOGO NECK PLATE (CONTOURED HEEL)

## BRIDGE

- BASE MODEL BRIDGE

## STRATOCASTER® BRIDGE

- AM VINTAGE SYNCHRONIZED TREMOLO
- CUSTOM SHOP VINTAGE STRAT TREMOLO
- 2-POINT CLASSIC PLAYER TREMOLO
- 2-POINT CUSTOM CLASSIC TREMOLO
- RSD STRAT® TREMOLO
- VINTAGE HARD-TAIL
- CUSTOM CLASSIC HARD-TAIL
- FLOYD ROSE® DOUBLE LOCKING

**TELECASTER® BRIDGE**

- '51 - '53 TELE® - BRASS SADDLES
- '54 - '57 TELE® - STEEL SADDLES
- '58 - '63 TELE® - THREADED SADDLES
- '64 - '66 TELE® - THREADED SADDLES
- '67 TELE® - SLOTTED STEEL SADDLES
- CUSTOM DELUXE TELE® BRIDGE
- RSD TELE® BRIDGE
- RSD HARDTAIL (SAWED OFF TELE®)
- BIGSBY® B-5 VIBRATO TAILPIECE

**PRECISION BASS®/JAZZ BASS® BRIDGE**

- VINTAGE 2-SADDLE BRIDGE
- VINTAGE THREADED SADDLES BRIDGE
- VINTAGE GROOVE SADDLES BRIDGE
- AMERICAN DELUXE BRIDGE
- RSD BASS BRIDGE

**JAZZMASTER® BRIDGE**

- RSD J-BRIDGE

**TUNING MACHINES**

- BASE MODEL TUNING MACHINES
- VINTAGE-STYLE
- VINTAGE-STYLE STAGGERED
- VINTAGE-STYLE LOCKING
- VINTAGE-STYLE "F"
- MODERN LOCKING
- MODERN LOCKING STAGGERED

**PICKGUARD**

- BASE MODEL PICKGUARD
- 1-PLY WHITE
- 1-PLY EGGSHELL
- 1-PLY PARCHMENT
- 1-PLY BLACK
- 1-PLY BLACK PHENOLIC LAMINATE
- 3-PLY WHITE
- 3-PLY EGGSHELL
- 3-PLY PARCHMENT
- 3-PLY MINT GREEN
- 3-PLY BLACK
- 3-PLY WHITE PEARLOID
- 3-PLY BLACK PEARLOID
- 4-PLY BROWN SHELL
- ANODIZED GOLD

**CONTROL KNOBS**

- BASE MODEL CONTROL KNOBS

**STRATOCASTER® KNOBS**

- WHITE
- EGGSHELL
- PARCHMENT
- VINTAGE WHITE
- BLACK

**TELECASTER®/PRECISION BASS® KNOBS**

- VINTAGE KNURLED
- ALUMINUM KNURLED

**STRATOCASTER® PICKUP COVERS**

- BASE MODEL COVERS
- WHITE
- EGGSHELL WHITE
- PARCHMENT WHITE
- VINTAGE WHITE
- BLACK
- LIPSTICK COVERS (EACH)

**WIRING**

- BASE MODEL WIRING

**STRATOCASTER® WIRING**

- VINTAGE STRAT®
- MODERN STRAT®
- VINTAGE MODIFIED #1
- VINTAGE MODIFIED #2 W/ TONE-SAVER
- STRAT® BLENDER
- STRAT® BLENDER W/ GREASEBUCKET
- FAT '50S STRAT®
- FAT '50S W/ GREASEBUCKET
- FAT '50S HALF BLENDER
- H-S-S POMO STRAT® 250/500
- H-S-H CONFIGURATION
- H-H CONFIGURATION
- OTHER STRAT® WIRING \_\_\_\_\_

**TELECASTER®/ESQUIRE WIRING**

- VINTAGE ESQUIRE® (1-PICKUP)
- FULL THROTTLE ESQUIRE® (1-PICKUP)
- COCKED-WAH ESQUIRE® (1-PICKUP)
- '51 NOCASTER® ('50-'52 BLACKGUARD)
- '51 MODIFIED NOCASTER®
- '53-'59 VINTAGE TELE®
- MODERN TELE®
- MODERN TELE® W/ GREASEBUCKET
- MODERN TELE® W/ 4-WAY SWITCH
- FAT '50S TELE®
- HOTSHOT TELE® (3-PU TELE)
- HS TELE® DUAL-STACK 250/500
- FAT '50S DUAL P90/HH TELE®
- OTHER TELE® WIRING \_\_\_\_\_

**JAZZ BASS® WIRING**

- VINTAGE JAZZ BASS® W/ CONCENTRIC KNOBS

**MISCELLANEOUS ELECTRONICS**

- 3-WAY SWITCH (STRAT®)
- REVERSE TELE® CONTROL PLATE
- TONE-SAVER TREBLE BLEED
- GREASEBUCKET TONE CONTROL
- TBX TONE CONTROL
- NO-LOAD TONE CONTROL
- S-1 SWITCH
- S-1 FUNCTION \_\_\_\_\_

## PICKUPS

PICKUPS	N	M	B
BASE MODEL PICKUPS*	<input type="checkbox"/>	<input type="checkbox"/>	<input type="checkbox"/>
RWRP MIDDLE PICKUP		<input type="checkbox"/>	
<b>STRATOCASTER PICKUPS (PRICE PER PICKUP)</b>			
'54 STRAT®	<input type="checkbox"/>	<input type="checkbox"/>	<input type="checkbox"/>
'50S STRAT®	<input type="checkbox"/>	<input type="checkbox"/>	<input type="checkbox"/>
FAT '50S STRAT®	<input type="checkbox"/>	<input type="checkbox"/>	<input type="checkbox"/>
'60S STRAT®	<input type="checkbox"/>	<input type="checkbox"/>	<input type="checkbox"/>
FAT '60S STRAT®	<input type="checkbox"/>	<input type="checkbox"/>	<input type="checkbox"/>
'58 STRAT®	<input type="checkbox"/>	<input type="checkbox"/>	<input type="checkbox"/>
'59 STRAT®	<input type="checkbox"/>	<input type="checkbox"/>	<input type="checkbox"/>
'65 STRAT®	<input type="checkbox"/>	<input type="checkbox"/>	<input type="checkbox"/>
'66 STRAT®	<input type="checkbox"/>	<input type="checkbox"/>	<input type="checkbox"/>
'69 STRAT®	<input type="checkbox"/>	<input type="checkbox"/>	<input type="checkbox"/>
TEXAS SPECIAL STRAT®	<input type="checkbox"/>	<input type="checkbox"/>	<input type="checkbox"/>
<b>HAND-WOUND STRAT® PICKUPS (PRICE PER PICKUP)</b>			
ADD JOSEFINA MASTER WOUND UPGRADE	<input type="checkbox"/>	<input type="checkbox"/>	<input type="checkbox"/>
HW '50S STRAT®	<input type="checkbox"/>	<input type="checkbox"/>	<input type="checkbox"/>
HW FAT '50S STRAT®	<input type="checkbox"/>	<input type="checkbox"/>	<input type="checkbox"/>
HW '55 STRAT®	<input type="checkbox"/>	<input type="checkbox"/>	<input type="checkbox"/>
HW '56 STRAT®	<input type="checkbox"/>	<input type="checkbox"/>	<input type="checkbox"/>
HW '57 STRAT®	<input type="checkbox"/>	<input type="checkbox"/>	<input type="checkbox"/>
HW '59 STRAT®	<input type="checkbox"/>	<input type="checkbox"/>	<input type="checkbox"/>
HW '60 STRAT®	<input type="checkbox"/>	<input type="checkbox"/>	<input type="checkbox"/>
HW FAT '60 STRAT®	<input type="checkbox"/>	<input type="checkbox"/>	<input type="checkbox"/>
HW '60/'63 STRAT®	<input type="checkbox"/>	<input type="checkbox"/>	<input type="checkbox"/>
HW '64 STRAT®	<input type="checkbox"/>	<input type="checkbox"/>	<input type="checkbox"/>
HW FAT '64 STRAT®	<input type="checkbox"/>	<input type="checkbox"/>	<input type="checkbox"/>
HW '65 STRAT®	<input type="checkbox"/>	<input type="checkbox"/>	<input type="checkbox"/>
HW '66 STRAT®	<input type="checkbox"/>	<input type="checkbox"/>	<input type="checkbox"/>
HW '69 STRAT®	<input type="checkbox"/>	<input type="checkbox"/>	<input type="checkbox"/>
HW TEXAS SPECIAL STRAT®	<input type="checkbox"/>	<input type="checkbox"/>	<input type="checkbox"/>
HW TROPOSPHERE™ STRAT®	<input type="checkbox"/>	<input type="checkbox"/>	<input type="checkbox"/>
HW MASTER DESIGN BONE TONE STRAT®	<input type="checkbox"/>	<input type="checkbox"/>	<input type="checkbox"/>
HW DUAL-MAG STRAT®	<input type="checkbox"/>	<input type="checkbox"/>	<input type="checkbox"/>
HW DUAL-MAG II STRAT®	<input type="checkbox"/>	<input type="checkbox"/>	<input type="checkbox"/>
HW EL DIABLO STRAT®	<input type="checkbox"/>	<input type="checkbox"/>	<input type="checkbox"/>
HW TOMATILLO STRAT®	<input type="checkbox"/>	<input type="checkbox"/>	<input type="checkbox"/>
HW ANCHO POBLANO STRAT®	<input type="checkbox"/>	<input type="checkbox"/>	<input type="checkbox"/>
<b>OTHER STRAT® PICKUPS (PRICE PER PICKUP)</b>			
FENDER® VINTAGE NOISELESS	<input type="checkbox"/>	<input type="checkbox"/>	<input type="checkbox"/>
DUNCAN® SLDS-1 HOT RAILS™	<input type="checkbox"/>	<input type="checkbox"/>	<input type="checkbox"/>
DUNCAN SSL-3 HOT STRAT®	<input type="checkbox"/>	<input type="checkbox"/>	<input type="checkbox"/>

DUNCAN LI'L SCREAMIN' DEMON™	<input type="checkbox"/>	<input type="checkbox"/>	<input type="checkbox"/>
DUNCAN SLS-1 LIPSTICK TUBE	<input type="checkbox"/>	<input type="checkbox"/>	<input type="checkbox"/>
<b>TELECASTER® PICKUPS (PRICE PER PICKUP)</b>			
ORIGINAL BLACKGUARD TELE® (OBG)	-	-	<input type="checkbox"/>
'51 TELECASTER®/NOCASTER®	<input type="checkbox"/>	-	<input type="checkbox"/>
'56/'57 TELE®	<input type="checkbox"/>	-	<input type="checkbox"/>
'63 TELE®	<input type="checkbox"/>	-	<input type="checkbox"/>
'64 TELE®	<input type="checkbox"/>	-	<input type="checkbox"/>
'67 TELE®	<input type="checkbox"/>	-	<input type="checkbox"/>
TEXAS SPECIAL TELE®	<input type="checkbox"/>	-	<input type="checkbox"/>
TWISTED TELE®	<input type="checkbox"/>	-	<input type="checkbox"/>
<b>HAND-WOUND TELE® PICKUPS (PRICE PER PICKUP)</b>			
ADD JOSEFINA MASTER WOUND UPGRADE	<input type="checkbox"/>	-	<input type="checkbox"/>
HW ORIGINAL BLACKGUARD (OBG)	-	-	<input type="checkbox"/>
HW '50/'51 BLACKGUARD	<input type="checkbox"/>	-	<input type="checkbox"/>
HW '50/'51 CRUSHED BLACKGUARD	-	-	<input type="checkbox"/>
HW '51 NOCASTER®	<input type="checkbox"/>	-	<input type="checkbox"/>
HW '51 LOADED NOCASTER®	<input type="checkbox"/>	-	<input type="checkbox"/>
HW '55/'56 TELE®	<input type="checkbox"/>	-	<input type="checkbox"/>
HW '58 TELE®	<input type="checkbox"/>	-	<input type="checkbox"/>
HW '63 TELE®	<input type="checkbox"/>	-	<input type="checkbox"/>
HW '64 TELE®	<input type="checkbox"/>	-	<input type="checkbox"/>
HW '67 TELE®	<input type="checkbox"/>	-	<input type="checkbox"/>
HW TOMATILLO TELE®	<input type="checkbox"/>	-	<input type="checkbox"/>
HW TWISTED TELE®	<input type="checkbox"/>	-	<input type="checkbox"/>
HW TEXAS SPECIAL TELE®	<input type="checkbox"/>	-	<input type="checkbox"/>
HW RED HOT TELE®	<input type="checkbox"/>	-	<input type="checkbox"/>
<b>OTHER TELE® PICKUPS (PRICE PER PICKUP)</b>			
FENDER® VINTAGE NOISELESS	<input type="checkbox"/>	-	<input type="checkbox"/>
DUNCAN FIVE-TWO TELE®	<input type="checkbox"/>	-	<input type="checkbox"/>
DUNCAN QUARTER POUND	<input type="checkbox"/>	-	<input type="checkbox"/>
DUNCAN LITTLE '59™	<input type="checkbox"/>	-	<input type="checkbox"/>
<b>JAZZMASTER®/JAGUAR®/BASS VI</b>			
VINTAGE JAZZMASTER®	<input type="checkbox"/>	-	<input type="checkbox"/>
VINTAGE JAGUAR®/BASS VI	<input type="checkbox"/>	-	<input type="checkbox"/>
HW VINTAGE JAZZMASTER®	<input type="checkbox"/>	<input type="checkbox"/>	<input type="checkbox"/>
HW VINTAGE JAGUAR®/BASS VI	<input type="checkbox"/>	<input type="checkbox"/>	<input type="checkbox"/>
<b>HUMBUCKER &amp; P90 PICKUPS (PRICE PER PICKUP)</b>			
FENDER® CUNIFE HUMBUCKER	<input type="checkbox"/>	-	<input type="checkbox"/>
FENDER® SHAWBUCKER	<input type="checkbox"/>	-	<input type="checkbox"/>
EVH® WOLFGANG HUMBUCKER	<input type="checkbox"/>	-	<input type="checkbox"/>
EVH FRANKENSTEIN HUMBUCKER	<input type="checkbox"/>	-	<input type="checkbox"/>
DUNCAN SH-159	<input type="checkbox"/>	-	<input type="checkbox"/>
DUNCAN SH-55 SETH LOVER	<input type="checkbox"/>	-	<input type="checkbox"/>

DUNCAN SH-4 JB BRIDGE	<input type="checkbox"/>	-	<input type="checkbox"/>
DUNCAN TB-4 TREMUCKER™	<input type="checkbox"/>	-	<input type="checkbox"/>
DUNCAN SH-PG1 PEARLY GATES™	<input type="checkbox"/>	-	<input type="checkbox"/>
DUNCAN ANTIQUITY HUMBUCKER	<input type="checkbox"/>	-	<input type="checkbox"/>
DUNCAN APH-1 ALNICO II PRO™	<input type="checkbox"/>	-	<input type="checkbox"/>
DUNCAN TBAPH-1 ALNICO II PRO	<input type="checkbox"/>	-	<input type="checkbox"/>
DUNCAN SCREAMIN' DEMON	<input type="checkbox"/>	-	<input type="checkbox"/>
DUNCAN SH-8 INVADER	<input type="checkbox"/>	-	<input type="checkbox"/>
TV JONES® CLASSIC (TELE® ONLY)	<input type="checkbox"/>	-	<input type="checkbox"/>
TV JONES® CLASSIC PLUS (TELE® ONLY)	<input type="checkbox"/>	-	<input type="checkbox"/>
TV JONES® POWER 'TRON (TELE® ONLY)	<input type="checkbox"/>	-	<input type="checkbox"/>
TV JONES® POWER 'TRON PLUS (TELE® ONLY)	<input type="checkbox"/>	-	<input type="checkbox"/>
TV JONES® SUPER 'TRON (TELE® ONLY)	<input type="checkbox"/>	-	<input type="checkbox"/>
TV JONES® MAGNA 'TRON (TELE® ONLY)	<input type="checkbox"/>	-	<input type="checkbox"/>
FENDER® CUSTOM P-90	<input type="checkbox"/>	-	<input type="checkbox"/>
DUNCAN VINTAGE P90	<input type="checkbox"/>	-	<input type="checkbox"/>
DUNCAN ANTIQUITY P90	<input type="checkbox"/>	-	<input type="checkbox"/>

**BASS PICKUPS****N M B****PRECISION BASS® PICKUPS**

'55 PRECISION BASS®	-	<input type="checkbox"/>	-
'57 PRECISION BASS®	-	<input type="checkbox"/>	-
'59 - '62 PRECISION BASS®	-	<input type="checkbox"/>	-
'59 - '62 PRECISION BASS® (FLAT POLES)	-	<input type="checkbox"/>	-
HW '55 PRECISION BASS®	-	<input type="checkbox"/>	-
HW '57 PRECISION BASS®	-	<input type="checkbox"/>	-
HW '62 PRECISION BASS®	-	<input type="checkbox"/>	-
HW '65 - '70 PRECISION BASS®	-	<input type="checkbox"/>	-

**JAZZ BASS® PICKUPS (PRICE PER PICKUP)**

VINTAGE JAZZ BASS®	<input type="checkbox"/>	-	<input type="checkbox"/>
'75 JAZZ BASS®	<input type="checkbox"/>	-	<input type="checkbox"/>
CUSTOM CLASSIC JAZZ BASS®	<input type="checkbox"/>	-	<input type="checkbox"/>
HW VINTAGE JAZZ BASS®	<input type="checkbox"/>	-	<input type="checkbox"/>
HW '75 JAZZ BASS®	<input type="checkbox"/>	-	<input type="checkbox"/>

**PICKUP SPECS**

HAND-WOUND STRAT®	NOMINAL DC RESISTANCE +/- 10%				WIRE	MAGNETS	STAGGER	NOTES
	NECK	MIDDLE	MID-RWRP	BRIDGE				
H/W '50S STRAT®	6.12K	6.12K	6.12K	6.39K	FORMVAR	ALNICO 5	VINTAGE	CALIBRATED SET
H/W FAT '50S STRAT®	6.26K		6.34K	6.48K	FORMVAR	ALNICO 5	VINTAGE	
H/W '55 STRAT®	5.60K	5.60K		5.60K	FORMVAR	ALNICO 3	VINTAGE LOW "G"	
H/W '56 STRAT®	5.98K		5.98K	6.22K	FORMVAR	ALNICO 5	CUSTOM LOW "G"	CALIBRATED SET
H/W '57 STRAT®	6.02K		6.02K	6.39K	FORMVAR	ALNICO 5	VINTAGE	CALIBRATED SET
H/W '59 STRAT®	5.80K	5.80K		5.80K	FORMVAR	ALNICO 5	VINTAGE	
H/W '60S STRAT®	5.83K	5.83K	5.83K	5.83K	FORMVAR	ALNICO 2	VINTAGE	
H/W FAT 60'S STRAT®	6.64K	6.64K	6.64K	6.64K	FORMVAR	ALNICO 2	VINTAGE	
H/W '60-'63 STRAT®	6.20K		6.35K	6.47K	FORMVAR	ALNICO 5	VINTAGE	CALIBRATED SET
H/W '64 STRAT®	5.31K		5.56K	5.81K	ENAMEL	ALNICO 5	VINTAGE	CALIBRATED SET
H/W FAT '64 STRAT®	5.90K		5.98K	6.05K	ENAMEL	ALNICO 5	VINTAGE	CALIBRATED SET
H/W '65 STRAT®	6.27K	6.27K	6.27K	6.27K	POLYSOL	ALNICO 5	VINTAGE	
H/W VINTAGE '65 STRAT®	5.90K	5.90K	5.90K	5.90K	ENAMEL	ALNICO 5	VINTAGE	
H/W '69 STRAT®	5.61K	5.61K	5.61K	5.61K	ENAMEL	ALNICO 5	VINTAGE	
H/W TEXAS SPECIAL STRAT®	5.94K		6.27K	6.56K	ENAMEL	ALNICO 5	VINTAGE	CALIBRATED SET
H/W DUAL-MAG STRAT®	5.79K		6.05K	6.27K	FORMVAR	ALNICO 5/2	VINTAGE	CALIBRATED SET
H/W DUAL-MAG II STRAT®	5.85K		5.90K	5.95K	FORMVAR	ALNICO 5/2	CUSTOM LOW "G"	
H/W TOMATILLO STRAT®	6.00K	6.00K	6.00K	6.27K	FORMVAR	ALNICO 2	VINTAGE	CALIBRATED SET
H/W RED HOT STRAT®	6.8K	7.2K		7.6K	FORMVAR	ALNICO 5	VINTAGE	CALIBRATED SET
H/W POBLANO STRAT®	6.25K		6.47K		FORMVAR	ALNICO 3	VINTAGE LOW "G"	
H/W POBLANO STRAT®				6.27K	ENAMEL	ALNICO 5	FLUSH	
H/W EL DIABLO STRAT®	5.55K		5.93K		ENAMEL	ALNICO 5	CUSTOM LOW "G"	CALIBRATED SET
H/W EL DIABLO STRAT®				6.34K	ENAMEL	ALNICO 5	FLUSH W/HIGH "D"	
H/W TROPOSPHEHRE STRAT®	5.57K		5.62K	5.62K	FORMVAR	ALNICO 5	VINTAGE	CALIBRATED SET
H/W M.D. BONE TONE STRAT®	5.96K	6.21K		5.95K	FORMVAR	ALNICO 2	VINTAGE	CALIBRATED SET

\*For base model specifications see page 17

# PICKUP SPECS

NOMINAL DC RESISTANCE +/- 10%								
NON HAND-WOUND STRAT	NECK	MIDDLE	MID-RWRP	BRIDGE	WIRE	MAGNETS	STAGGER	NOTES
'50S STRATOCASTER®	6.12K	6.12K	6.12K	6.39K	FORMVAR	ALNICO 5	VINTAGE	CALIBRATED SET
FAT '50S STRATOCASTER®	6.26K	6.34K	6.48K	6.48K	FORMVAR	ALNICO 5	VINTAGE	CALIBRATED SET
'60S STRATOCASTER®	5.83K	5.83K	5.83K	5.83K	FORMVAR	ALNICO 2	VINTAGE	
'65 STRATOCASTER®	6.27K	6.27K	6.27K	6.27K	POLYSOL	ALNICO 5	VINTAGE	
'66 STRATOCASTER®	5.61K	5.61K	5.61K	5.61K	ENAMEL	ALNICO 5	VINTAGE	
'69 STRATOCASTER®	5.48K	5.48K	5.48K	5.48K	ENAMEL	ALNICO 5	VINTAGE	
TEXAS SPECIAL STRAT®	5.94K	6.27K	6.27K	6.56K	ENAMEL	ALNICO 5	VINTAGE	CALIBRATED SET
FENDER NOISELESS™	9.80K	9.80K	9.80K	9.80K	POLYSOL	ALNICO 2	CUSTOM	

NOMINAL DC RESISTANCE +/- 10%								
HAND-WOUND TELE	NECK	MIDDLE	MID-RWRP	BRIDGE	WIRE	MAGNETS	STAGGER	NOTES
H/W ORIGINAL BLACKGUARD "OBG"				10.49K	ENAMEL	ALNICO 5	FLUSH	
H/W '50-'51 BLACKGUARD	7.33K			9.73K	ENAMEL	NECK: ALNICO 5, BRIDGE: ALNICO 3	FLUSH	
H/W CRUSHED BLACKGUARD TELE				10.7K	ENAMEL	ALNICO 3	FLUSH	
H/W '51 NOCASTER®	7.90K			7.72K	ENAMEL	ALNICO 3	FLUSH	
H/W '51 LOADED NOCASTER®	7.88K			9.38K	ENAMEL	NECK: ALNICO 5, BRIDGE: ALNICO 3	FLUSH	
H/W '55-'56 TELECASTER®	6.15K			6.12K	ENAMEL	NECK: ALNICO 3, BRIDGE: ALNICO 5	NECK: FLUSH, BRIDGE: VINTAGE	
H/W '58 TELECASTER®	7.40K			6.60K	ENAMEL	NECK: ALNICO 3, BRIDGE: ALNICO 5	NECK: FLUSH, BRIDGE: VINTAGE	
H/W '63 TELECASTER®	7.37K			6.59K	ENAMEL	ALNICO 2	NECK: FLUSH, BRIDGE: VINTAGE	
H/W '64 TELECASTER®	7.35K			6.01K	ENAMEL	ALNICO 5	NECK: FLUSH, BRIDGE: VINTAGE	
H/W '67 TELECASTER®	5.57K			5.99K	ENAMEL	NECK: ALNICO 2, BRIDGE: ALNICO 5	NECK: FLUSH, BRIDGE: VINTAGE	
H/W 'TEXAS SPECIAL	9.02K			10.16K	ENAMEL	ALNICO 5	VINTAGE	
H/W 'TWISTED TELE'	5.95K			10.00K	ENAMEL	ALNICO 5	CUSTOM	
H/W 'TOMATILLO TELE'	8.70K			9.70K	ENAMEL	ALNICO 2	NECK: FLUSH, BRIDGE: VINTAGE	
H/W 'RED HOT TELE'	8.40K			12.36K	ENAMEL	NECK: ALNICO 2, BRIDGE: ALNICO 5	FLUSH	

NOMINAL DC RESISTANCE +/- 10%								
NON HAND-WOUND TELE	NECK	MIDDLE	MID-RWRP	BRIDGE	WIRE	MAGNETS	STAGGER	NOTES
'51 NOCASTER®	7.90K			7.72K	ENAMEL	ALNICO 3	FLUSH	
'56/'57 TELECASTER®	7.28K			7.12K	ENAMEL	ALNICO 5	FLUSH	
'63 TELECASTER®	7.37K			6.59K	ENAMEL	ALNICO 2	VINTAGE	
'67 TELECASTER®	5.57K			5.99K	ENAMEL	ALNICO 5	VINTAGE	
TEXAS SPECIAL	9.02K			10.16K	ENAMEL	ALNICO 5	VINTAGE	
TWISTED TELE®	5.95K			10.00K	ENAMEL	ALNICO 5	CUSTOM	
FENDER NOISELESS™	12.00K			8.60K	ENAMEL	ALNICO 2	CUSTOM	

NOMINAL DC RESISTANCE +/- 10%								
BASS	NECK	MIDDLE	MID-RWRP	BRIDGE	WIRE	MAGNETS	STAGGER	NOTES
H/W '55 PRECISION BASS®	6.22K				ENAMEL	ALNICO 3	FLUSH	
H/W '57 PRECISION BASS®	5.50K				ENAMEL	ALNICO 5	HIGH "A"	
H/W '62 PRECISION BASS®	5.20K				ENAMEL	ALNICO 5	FLUSH	
H/W '65-'70 PRECISION BASS®	6.30K				FORMVAR	ALNICO 5	FLUSH	
H/W VINTAGE JAZZ BASS®	7.30K			7.70K	ENAMEL	ALNICO 2	FLUSH	
H/W '75 JAZZ BASS®	7.89K			8.16K	ENAMEL	ALNICO 5	FLUSH	
VINTAGE NOISELESS™ JAZZ BASS®	7.25K			7.50K	POLYSOL	ALNICO 2	FLUSH	

\*Enamel wire pickups typically measure lower DCR vs. the same number of turns as FORMVAR





# CUSTOMER INFO

## CUSTOMER INFORMATION

NAME: \_\_\_\_\_

ADDRESS: \_\_\_\_\_

\_\_\_\_\_

CITY: \_\_\_\_\_

STATE: \_\_\_\_\_

PHONE #: \_\_\_\_\_

EMAIL: \_\_\_\_\_

DATE: \_\_\_\_\_

STORE: \_\_\_\_\_

CITY: \_\_\_\_\_

SALESPERSON: \_\_\_\_\_

**Final approval, verification and estimated delivery date must be verified by the Fender Custom Shop.**

NOTICE REGARDING USE OF HISTORIC PATENT NUMBERS/MARKINGS: FENDER is proud to offer some of the most iconic musical instruments and amplifiers of the past 60 years. Some FENDER products are intentional recreations or reissues of vintage guitars and amplifiers, and may therefore incorporate markings or text associated with original patents that have since expired. Specific examples of such models include patent numbers on the tremolo plates and decals of the JAGUAR® and JAZZMASTER® guitars, "Pat Pending" on some vintage TELECASTER® guitar bridge plates, and "Design and Circuits Patented" language on the control panels of certain model amplifiers in FENDER Vintage Modified, Vintage Reissue and Custom lines. Such markings are included only for the sake of historical accuracy, and are not intended to denote or imply live patents or ongoing patent protection.



FENDER CUSTOM SHOP | CORONA, CA. | USA

Please contact your Fender Custom Shop Showcase Dealer  
with your completed Design form for a quote.

To locate the nearest Custom Shop Showcase Dealer please visit  
[fendercustomshop.com](http://fendercustomshop.com)



LIMITED '60S THINLINE® STRATOCASTER®  
JOURNEYMAN RELIC®/CLOSET CLASSIC HARDWARE  
AGED NATURAL BLONDE  
9235700111